

MINES BRANCH
DEPARTMENT OF THE INTERIOR.

HONOURABLE FRANK OLIVER, M.P., MINISTER.

EUGENE HAANEL, PH. D. SUPERINTENDENT OF MINES.

MICA

ITS

Occurrence, Exploitation and Uses

BY

FRITZ CIRKEL, M.E.

OTTAWA, CANADA

1905.

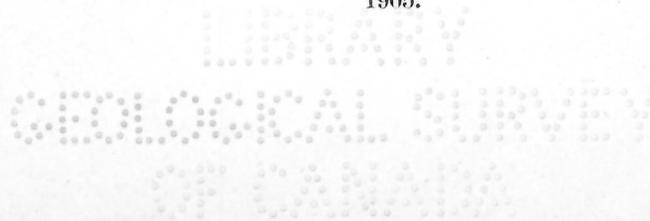



Occurrence of Mica in Blackburn Mine.

5147



ERRATA.

Page 68, 17th line from the top, for 18 read 12.

Page 105, figure 36 is upside down.

Page 105, 6th line from top, for Harzibagh read Hazaribagh.



**MINES BRANCH
DEPARTMENT OF THE INTERIOR.**

HONOURABLE FRANK OLIVER, M.P., MINISTER.

EUGENE HAANEL, PH. D. SUPERINTENDENT OF MINES.

MICA

ITS

Occurrence, Exploitation and Uses

BY

FRITZ CIRKEL, M.E.

OTTAWA, CANADA

1905.

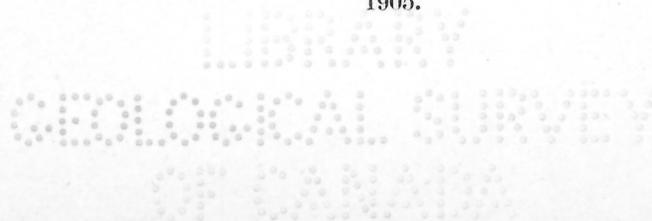

YERKES
YERKES OBSERVATORY
ARMING 75

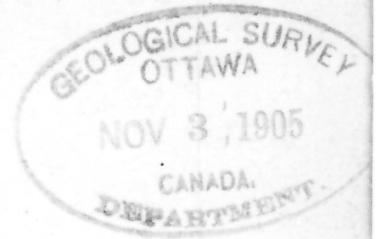

OTTAWA, 21st August, 1905.

SIR,—

I have the honour to transmit herewith a Report on Mica, its occurrence, exploitation and uses—the first of a series of publications to be issued by the Mines Branch on the Economic Minerals of Canada.

While due consideration is given in these publications to the geological features of the occurrences, special attention is paid to those topics which are of interest to the Mining Engineer and to those commercially interested.

I have the honour to be,

Sir,

Your obedient servant,

EUGENE HAANEL,
Superintendent of Mines.

HON. FRANK OLIVER, M.P.,
Minister of the Interior.
Ottawa.

2403

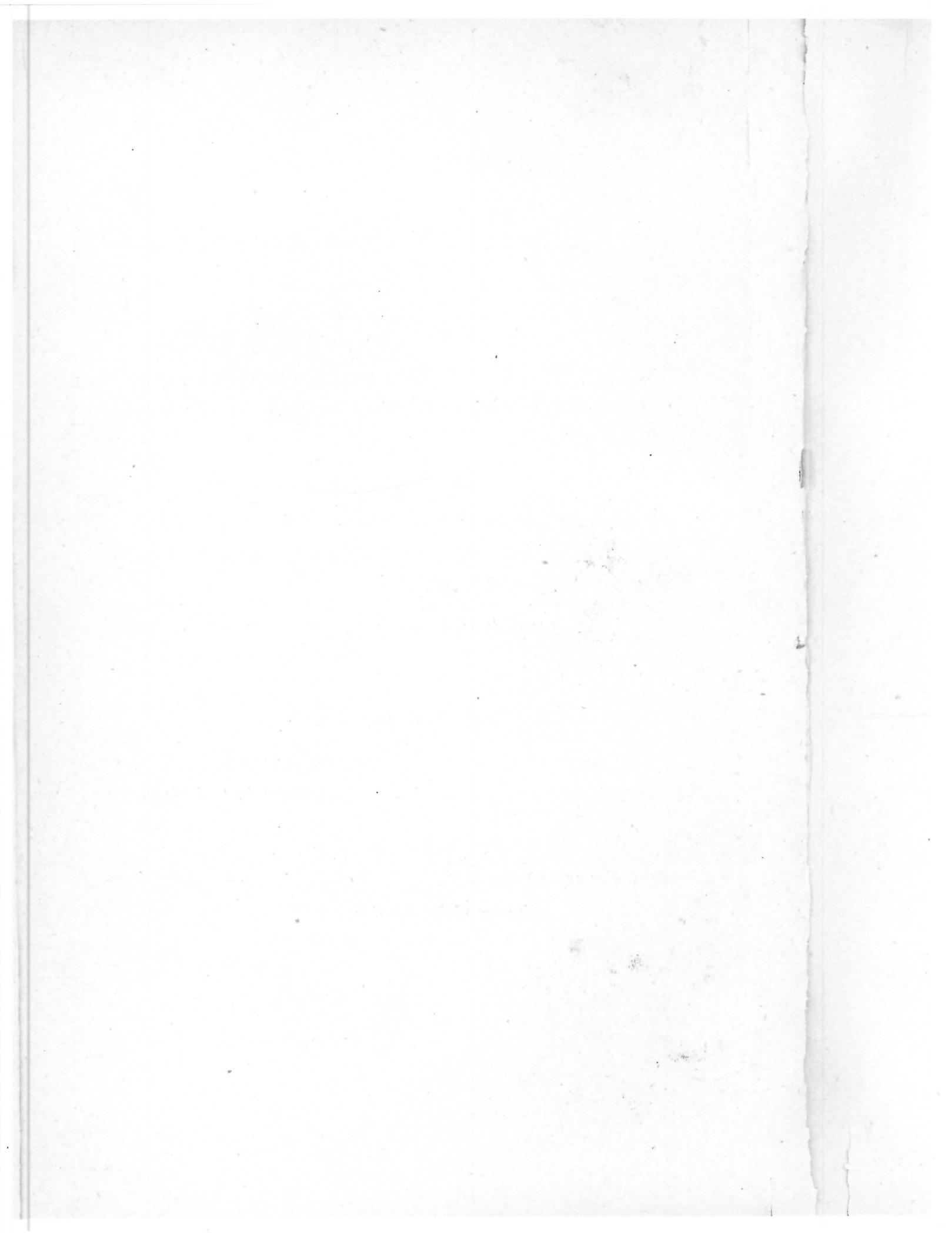



OTTAWA, 12th August, 1904.

SIR,—

You are instructed to proceed to the productive mica fields of the Dominion and collect all data and general information regarding the occurrence, mining and preparation for the market of the mineral "mica."

These data shall cover the following subjects:—

Physical and chemical qualities.

General topographic and geological features of the mica areas.

Mode of occurrence of the commercially useful deposits. A concise description of all the mica mines and prospects of value.

Status of the Canadian mica industry, its present condition and future prospects.

Statistics of production and exports.

Commercial application.

Occurrence of the mineral in foreign countries, especially India.

APPENDIX—Abstract of the laws governing the acquisition of mining properties and the mining of mica in the different provinces.

This report shall be accompanied by cuts through the deposits, illustrations and photographs pertaining strictly to the occurrence, the mining and preparation of mica.

Special attention shall be given to the commercial aspect of all the subjects above enumerated.

(Signed) EUGENE HAANEL,

Superintendent of Mines.

FRITZ CIRKEL, ESQ., M.E.,

80 Stanley Street,

Montreal, Que.

MONTREAL, January 10th, 1905.

SIR,—

In pursuance with your instructions, transmitted to me in your letter of the 12th of August, I have collected data and general information regarding the occurrence, mining and preparation for the market of mica and I now beg to hand over the annexed report thereon.

I have to acknowledge with sincere thanks the valuable aid you have given me by your suggestions regarding the carrying out of the work entrusted to me and especially in the compilation of this report.

I have the honour to be,

Sir,

Your obedient servant,

FRITZ CIRKEL.

DR. EUGENE HAANEL,
Superintendent of Mines,
Ottawa, Ont.

CHAPTER III.

THE MINING AND PREPARATION OF MICA.

<i>The Mining of Mica:</i>	PAGE
Mining methods. The winning of mica. Effect and cost of hand drilling. Effect and cost of machine drilling. Cost of blasting. Removal of debris. Construction of cable derricks. Disposal of rock and run of mine. Cost of mining. Percentage of mica in rock. Percentage of grades in the run of mine.. . . .	38-46
<i>Preparation of the Mica:</i>	
Trimming, Splitting, Ground mica	47-49

CHAPTER IV.

MICA MINES AND LOCATIONS.

Province of Quebec. Province of Ontario. Mica cutting factories	50-81
--	-------

CHAPTER V.

Status of the Canadian mica industry. Production, Export, Market and Prices	82-84
--	-------

CHAPTER VI.

Commercial applications of mica	85-98
--	-------

CHAPTER VII.

MICA IN FOREIGN COUNTRIES.

United States. Brazil. Norway. China. India. Comparison of Indian and Canadian mining methods. World's production of mica.. . . .	99-112
---	--------

APPENDIX.

Abstract from the Mining Law of the Province of Quebec	
Abstract from the Mines Act of the Province of Ontario	
Bibliography	113-132
Index	133-148

INTRODUCTION.

The exploitation and development of the natural resources of a country are largely dependent upon the manner in which all available information regarding the extent and economic character of those resources is placed before the public and especially before those most interested. In the majority of cases this information is scattered through technical and scientific journals and Government reports and is often practically inaccessible to those who desire to interest themselves in the exploitation of such resources. An exhaustive compilation of data and general information on the subject, in the form of a concise report, is needed and confidence in such a report will be proportionate to the amount and character of personal observations obtained in the field.

In the present monograph on mica an attempt has been made to fulfil such a purpose; the primary object being to give a synopsis of all that is known from a practical point of view on the subject generally, so that those who are now interested in this mineral as well as those who intend to pursue exploitations in the extensive mica fields of Canada may find such information given as will obviate the necessity of searching for it in our literature. By these means the writer hopes to stimulate a spirit of enquiry that will lead, not only to the successful development of large mica tracts now known to the public only by name, but also to a search for the mineral in other parts of the Dominion and to the development of those varieties of mica which now possess but little commercial value. In addition to the personal observations made by the author of this report and to the information derived from the reports issued by the Dominion and Provincial Governments, much information has been procured by means of a schedule of enquiry sent out to operators, of whom a large majority returned full replies.

In response to the effort made to obtain the latest and most accurate statistics possible a number of operators kindly consented to give the desired information but some, for private reasons, de-

clined to furnish these data. The writer was, therefore, obliged to compile the statistics of production from the Geological Survey Reports.

While due consideration has been given to the geological features of the different occurrences, chief attention has been paid to the commercial phase of the subject. This last expression suggests the exploitation of mica deposits commercially valuable. But occurrences of this character at present form only a small percentage of the many deposits scattered all over the mica fields of Canada. In other words the available mica supply is limited. It is essential, therefore, that the mica miner should be well acquainted with all the little difficulties attending the opening up of new mica deposits and that he should be well equipped with both theoretical and practical knowledge of mica itself. Successful mica-mining implies a large and varied experience in the field and many a good mica deposit has been abandoned on account of the lack of experience on the part of those who directed the operations.

CHAPTER I.

PHYSICAL AND CHEMICAL PROPERTIES AND GEOGRAPHICAL DISTRIBUTION OF THE MICAS.

THE MINERAL MICA.

Mica,* in its broader sense, comprises a group of minerals whose chief characteristics, distinguishing them from all other minerals, are the highly perfect basal cleavage and the great elasticity of the easily obtained thin laminæ. If we split up a mica crystal into sheets and continue to divide these sheets, we find that both their flexibility and their transparent qualities increase with the division of the laminæ and this division may be continued to the thickness of 1-1000th of an inch and could be carried, if we had sufficiently fine instruments, to a 1-300,000th of an inch.

Of the many different species of mica only the following three are of commercial importance:—

- 1.—*Muscovite*: The German "Kali-Glimmer," usually called potash-mica. Its predominating colour is white or pale yellow; it constitutes most of the white mica of the trade. The muscovite of India is of a ruby colour.
- 2.—*Phlogopite*: A magnesia-alumina mica of amber brown and black colour. It constitutes the greater part of the amber mica of commerce, as found in Canada.
- 3.—*Biotite*: Magnesia iron mica, generally black in colour.

CRYSTALLIZATION.

The different species of mica crystallize in the monoclinic system with a close approximation to rhombohedral symmetry. The form of the crystals is tabular, prismatic, passing into tapering forms with planes more or less rough and striated. (Figs. 1 and 2). They occur also as small scaly particles in plumose or compact massive forms constituting sometimes whole parts of the deposits, as in the case of phlogopite, but in this form mica is of no commercial value. Most crystals exhibit to a greater or less extent a distortion or variation from the ideal geometrical forms

*The name "mica" is derived from the Latin "micare," to shine, and in most languages its reflective and shining properties are expressed in some form or another. So in German we have "Glimmer" which means "shiner," in Arabic "Kaukabulaz," the star of the earth.

In many cases crystals are attached to each other or intergrown (Fig. 2) and in consequence of this are only partly developed.

Mica yields readily to the effects of disturbances in the formation in which it occurs, as is evidenced by the folded, contorted and twisted nature of the crystals. Under such conditions only a small percentage of the sheets mined are commercially valuable.

Muscovite twins (Fig. 3) and crystals with curved edges are not infrequent. As a rule, mica crystals imbedded in a hard rock matrix and free from any intergrowth yield the best and the highest percentage of useful mica sheets. These crystals are of perfect shape, the planes being generally well defined, while the absolutely smooth and even laminae give evidence of completed crystallization free from disturbing causes.

The thin laminae or films of mica are in general highly elastic, but those of muscovite are less so and are not so smooth as those of phlogopite.

Crystals of phlogopite occasionally contain primary crystals of the same mineral, which conform to the symmetry of the crystal

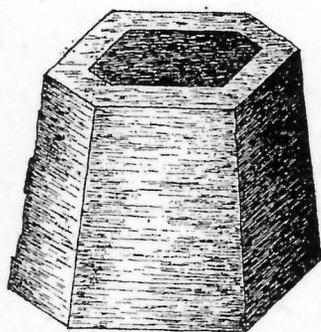

FIG. 1.—Crystal of Phlogopite with core of primary crystal.

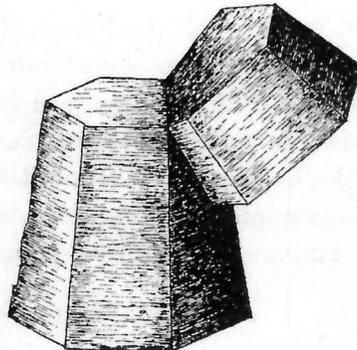

FIG. 2.—Intergrowth of Phlogopite crystals.

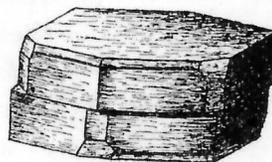

FIG. 3.—Twin crystal of Muscovite.

as a whole (Fig. 1). Sheets obtained from these double crystallizations exhibit no signs of imperfection as to lamination and, as a rule, can be used for any purpose for which mica is generally employed. Crystals of this kind have been mined in quantities on lot 15, range VIII., township of Templeton, Quebec.

The width of the folia varies from a few inches to several feet. Most of the mica mined, however, does not exceed four to six inches across. A majority of the larger crystals break up into small sheets producing the so-called "ribbon mica." The Lacey Mine near Sydenham, Ontario, is one of the mines in which crystals

of phlogopite of exceptionally large sizes have been found, some of them measuring seven feet across the cleavage planes.

PERCUSSION AND PRESSURE FIGURES.

In all micas percussion or pressure figures can be produced. The former may be obtained if a thin mica sheet be placed on a sheet of cardboard or similar plane surface and then sharply struck with a blunt needle. As a result, a six-rayed star is produced (Fig. 4), the branches of which intersect at the centre of percussion

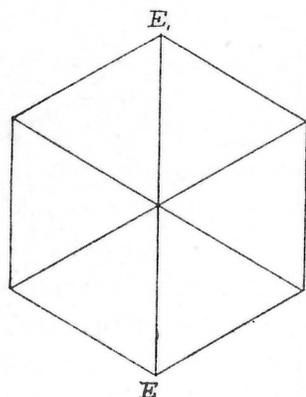

FIG. 4.—Percussion figure.

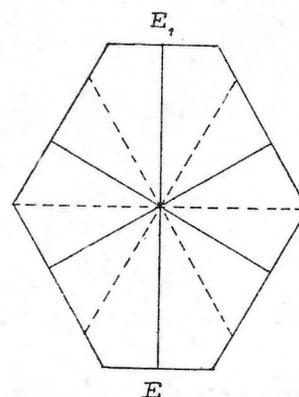

FIG. 5.—Percussion and pressure figure.

at angles of about 60° . The so-called pressure figures are obtained by subjecting a sheet of mica to a gradually increasing pressure with a blunt punch. This produces another six-rayed figure, with rays approximately bisecting the angles of the percussion figure. (Fig. 5). Often we find, imbedded in a rock matrix, crystals exhibiting these pressure figures as a result of pressure. Such crystals split up along these lines of inferior cohesion, forming pseudocrystal faces, which are inclined to the basal cleavage planes and give rise in the case of phlogopite to the so-called "ribbon mica."

COLOUR.

The colours of this mineral vary greatly. Some micas are colourless, others are white, pink, greenish, light brown or black. Some of the Bengal muscovite varieties are of a dark red tint which deepens into a ruby when in thick sheets. Amber coloured muscovite is rare, having been found only in the Nellore district of the Madras presidency. The colours and the character of the lustre in muscovite are changed by hydrous alteration of the mica or are altered by the presence of inclusions of some other mineral matter. A peculiar pearly or silvery lustre is displayed in some decomposed

muscovite varieties by removing exceedingly thin films from the cleavage planes.

The colour of biotite, the magnesium iron mica, is generally black.

The phlogopite varieties found in Canada are, even when in thin films, generally coloured a deep brown though they also show shades varying from a milky to a silver white or gray. The very dark or nearly black varieties sometimes contain, as chemical analysis has shown, a large amount of iron and for this reason their application to electrical purposes is limited. As a rule, the lighter shades occur in a matrix of soft, pale green pyroxene; where the latter is dark and hard, the mica too becomes both darker and harder. There are exceptions to this rule, but, generally speaking, the colour of phlogopite is in a large degree dependent upon the colour of the rock matrix. A beautiful pearly lustre is often produced by removing very thin laminae from the cleavage planes, but exposure to the light gradually destroys this effect. It appears that a pale or gray colour of the phlogopite is not desired by the trade. This kind of mica was mined last year in the Pike Lake Mine, North Burgess, Ontario. For some reason, not well understood, it is hard, unelastic and partly brittle.

All coloured micas display some degree of pleochroism or the property of exhibiting different colours in different directions by transmitted light. Some Canadian phlogopite species show occasionally distinct pleochroism. A beautiful crystal of twelve inches in diameter recently found in the Lacey mine exhibits a yellow brown colour when the light rays vibrate vertically and a red brown tint when the same vibrate parallel to the basal cleavage plane.

INTERNAL IMPERFECTIONS AND INCLUSIONS.

The transparency of mica sheets is often destroyed by disturbed crystallization or by impurities taken up from the solution during the process of development. These inclusions generally appear in films or very thin plates between the cleavage planes. The most common of these inclusions in muscovite are films of feldspar, but in phlogopite the inclusions are calcite, crystals of apatite, feldspar and quartz and they are sometimes so numerous as to render the crystal entirely unfit for use. Muscovite crystals occasionally contain small crystals of beryl, needles of black and red tourmaline, crystals of quartz, feldspar, garnet and zircon, the thin laminae being frequently stained with the colour of the

enclosed crystal. Red tourmaline stains, for instance, are found in the beautiful mica sheets obtained from the Villeneuve mine in Buckingham, Que. Brown or red films of iron oxide, though seldom seen in phlogopite and muscovite, are often met with in biotite.

HARDNESS.

The degree of hardness of all the micas lies between gypsum and calcite or between 2 and 3, Mohs' scale, and is considerably higher than that of talc from which mica can be readily distinguished. Loose sheets found in the humus as a result of decomposition of the crystals are soft, have an unctuous aspect and, as a rule, the degree of hardness is nearer 2 than 3. Crystals, however, which have been subjected to earth pressure or other disturbances during crystallization deliver hard, unelastic sheets and are not desirable for commercial purposes.

Generally, a high degree of hardness is looked upon with disfavour in the trade, indeed, for electrical purposes those sheets that can be scratched with the finger nail are much preferred.

CHEMICAL COMPOSITION.

All micas can be classified into two groups, the aluminobasic micas, comprising muscovite and all related species, and the ferromagnesian micas, comprising phlogopite and biotite. Muscovite is characterized by its high contents of alumina and potash; in the ferro-magnesian group phlogopite is more essentially magnesian, whilst biotite is distinctly ferruginous.

The following table represents the theoretical compositions of the different species:—

MUSCOVITE	}	Silica	45.2
		Alumina	38.5
		Potash	11.8
		Water	4.5
			<hr/>
			100.00
PHLOGOPITE	}	Silica	44.2
		Alumina	10.8
		Magnesia	29.4
		Potash	9.9
		Water	5.7
			<hr/>
			100.00
BIOTITE	}	Silica	39.9
		Alumina and Ferric Oxide	22.9
		Ferrous Oxide	16.0
		Magnesia	8.8
		Potash	10.4
		Water	2.0
			<hr/>
			100.00

All micas, however, contain a certain amount of impurities which render their composition slightly different from that given in the above table.

Noted chemists, such as Hautefeuille, Chrustschoff and Doelter, have artificially prepared small mica crystals according to these analyses, while Vogt has observed the occurrence of crystals in furnace slag. Up to the present no crystals of the size demanded by the trade have been artificially prepared, nor is it likely that they ever will be. These experiments are, however, of special scientific interest inasmuch as the formation of mica at the expense of other silicate minerals has been demonstrated.

GEOGRAPHICAL DISTRIBUTION OF THE MICAS.

The distribution of mica over the globe is very general. It occurs in scaly particles as essential constituents of many metamorphic and eruptive rocks such as gneiss and granite but in this mode of occurrence it is of geological and lithological importance only. As an economic mineral, as a mineral of commercial value, occurring as deposits of crystals of large size, which split up easily into fine merchantable sheets, mica is found in only three countries. British India and the United States produce the muscovite and Canada produces all the three varieties. As the primary object of this paper is the description of the Canadian deposits, those of India and the United States will be only briefly dealt with.

CHAPTER II.

MUSCOVITE AND PHLOGOPITE.

Muscovite.

GEOLOGICAL OCCURRENCE.

Muscovite, the most common of the micas, is named from Muscovy, a part of Eastern Russia where the mineral is found. Its exploitation in Canada has been attended with many difficulties. The great dispersion of the deposits all over the country, their sporadic and sometimes erratic occurrence and the difficulties of transportation are factors which heavily handicap the growth of this young industry.

The occurrence of this mica is confined, more or less, to pegmatite dikes, masses, lenses, sheets or veins, which in character may be called a very coarse granite, consisting of feldspar and quartz in variable quantities. These dikes occur in the Laurentian formation and in many cases have been involved in structural

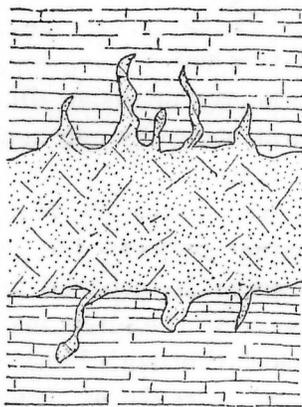

FIG. 6—Pegmatite Dike.

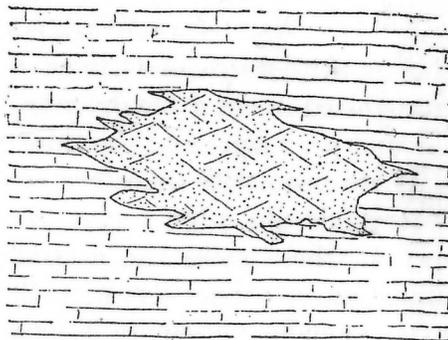

FIG. 7.—Pegmatite Dike.

modifications of the enclosing rocks, evidences of which may be noticed in the regions of the dikes where the crystals form large accumulations.

The pegmatites penetrate the gneiss formation along and sometimes across its strike. In the majority of cases, however, it is observed that they conform with the strike of the country rock (Figs. 6 and 7) and this may be due to the fact that the formation is more easily disrupted along than across its strike.

When, as often happens, a pegmatite dike is interrupted in its strike by a fault of the country rock (Fig. 8) the dike mass is not only thicker along the line of fault but this thicker portion contains more mica crystals than the other parts of the dike.

The intrusive character of the pegmatite is evidenced in most cases by its sending off spurs into the mass of gneiss, by the fact that dikes intersect the pyroxene rock and, further, by the presence of inclusions of greyish or reddish gneiss. In some places

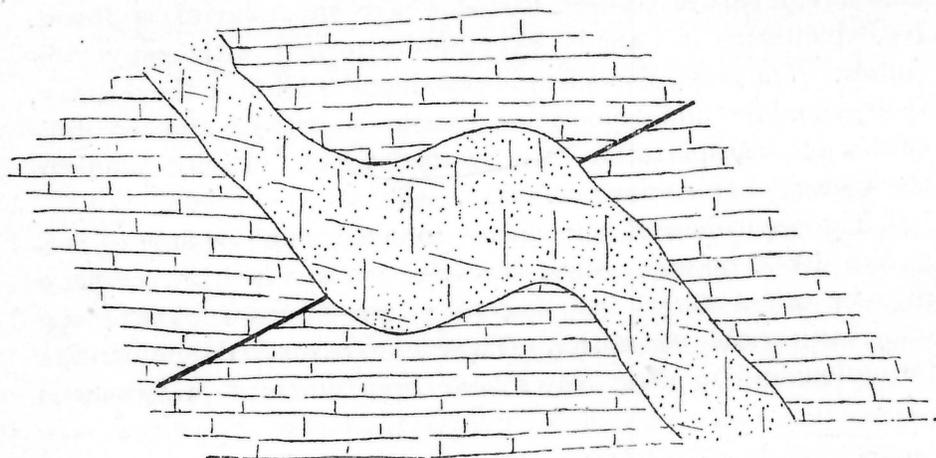

FIG. 8.—Pegmatite Dike in Faulted Country Rock.

in the country north of Ottawa three distinctly intrusive dikes are recognized in the same opening, the oldest being the pyroxene, the second pegmatite and the third a black trap.

Where pegmatite dikes are associated with pyroxene, phlogopite crystals are often found on the contact between the two rocks. In these cases the crystals show some disturbance and modification in connection with the intrusion of the dike mass.

Occasionally muscovite is found in association with biotite.* In Methuen township, Peterborough, Ontario, a range of syenite hills contains many intersecting veins and occurrences of nepheline in which at or near the surface crystals of white mica occur, the basal planes measuring 3 by 10 inches and 3 by 4 inches. At a depth of fifteen feet biotite crystals were associated with the muscovite containing inclusions of pure corundum. At a depth of forty feet one of the nepheline veins terminated in a solid mass of corundum, muscovite and biotite.

These nepheline veins are, according to Dr. Adams, syenite

*Mr. Morrison, discussion on Mica Deposits at the annual meeting of the Canadian Mining Institute, 1904.

pegmatites, having no quartz and being composed of feldspar and the two micas mentioned.

Pegmatite dikes vary in thickness from a few inches to more than 250 feet and can be traced for a distance of fifty or a hundred feet in the case of the smaller ones and to several hundred feet in some of the larger. Occasionally irregular in outline, they send out branches or spurs in every direction. No uniformity in the dip has been noticed, but it varies from vertical to horizontal through intermediate angles.

PETROGRAPHIC CHARACTER OF THE PEGMATITE.

As to the constituents of the pegmatite dikes, either feldspar or quartz predominates, an even distribution of both minerals through the dike matrix is generally rare. The quartz is, usually, vitreous, very clear, occasionally a little pink coloured. The feldspar is a white orthoclase, sometimes opalescent and occasionally with a pale green tint. In the latter state it is used for decorative purposes and as gems under the name of amazonstone.

When the feldspar predominates and occurs in large masses without any other impurities, it can be employed with advantage in the manufacture of porcelain, as at the Villeneuve mine near Buckingham.

In addition to these common minerals there occur many others with a varying degree of rarity. In some regions ten or more of these accessory species are observed in a single dike, while the dikes in other places are almost destitute of them. Amongst these minerals may be mentioned: Tourmaline, garnet, fluorspar, beryl, epidote and zircon and also all the different classes of minerals containing rare earths, such as samarskite, monazite and pitchblende.

No serious attempt, however, has yet been made in Canada to mine any of the minerals mentioned above.

MODE OF OCCURRENCE OF MUSCOVITE MICA.

As a rule crystals of muscovite mica of commercial value need not be looked for in dikes of less than three or four feet in width. There have been instances in the Ottawa valley, in the township of Wakefield, where crystals measuring from four to six inches across the basal planes have been found in small dikes, but they occur so sparingly that profitable mining cannot be pursued. On the other hand, some of the largest dikes contain no mica of

commercial size and in the absence of any leading indications it is difficult to say which dike is likely to contain muscovite mica in payable quantities.

As to the distribution of this mica in the dike, the crystals are generally scattered promiscuously through the matrix, while larger vein-like aggregations are observed near the contact with the adjacent formation. Cavities lined with crystals are also found along this contact and as a rule the mica obtained therefrom is of superior quality, presumably on account of the absence of any disturbing influences during the process of its formation. The form of most of the crystals is tabular, though some are tapering, with rough and striated side planes. As to the size of the crystals, all gradations are obtained, from those of commercial sizes down to scales of microscopic dimensions, such as occur in the granite. Marketable sheets of eighteen and twenty-four inches across have been found in the Villeneuve mine.

Location of Muscovite Mica Occurrences.

Pegmatite veins or dikes occur throughout Canada in a very large number of places where the Laurentian formation is exposed, but large areas of this rock are concealed by the extensive mantles of sedimentary strata.

Many of the deposits described hereafter have yielded marketable sheets, while others are mere prospects which by their appearance give encouragement for further exploitation, but it is well to keep a note of all deposits of pegmatite, whether profitable at present or not, as illustrating their extent and the various conditions under which they occur.

The best deposits so far discovered are those of the Saguenay district, situated at the lower St. Lawrence river below Quebec. Besides these there are deposits to the north of Ottawa, in the vicinity of Mattawa, at several places in Ontario, and recently discovered in British Columbia.

PROVINCE OF QUEBEC.

Saguenay District.

On the east side of the Saguenay river a number of coarse pegmatite veins occur, cutting the dioritic gneiss. This region is not surveyed or thoroughly explored, but since 1891 and 1892 constant discoveries have been made, some of them of very large

extent. The mica generally found here has a kind of dark rose colour when in thick sheets. The principal deposits have been found in the townships of Bergeronnes, Tadousac and Escoumains (Fig. 9).

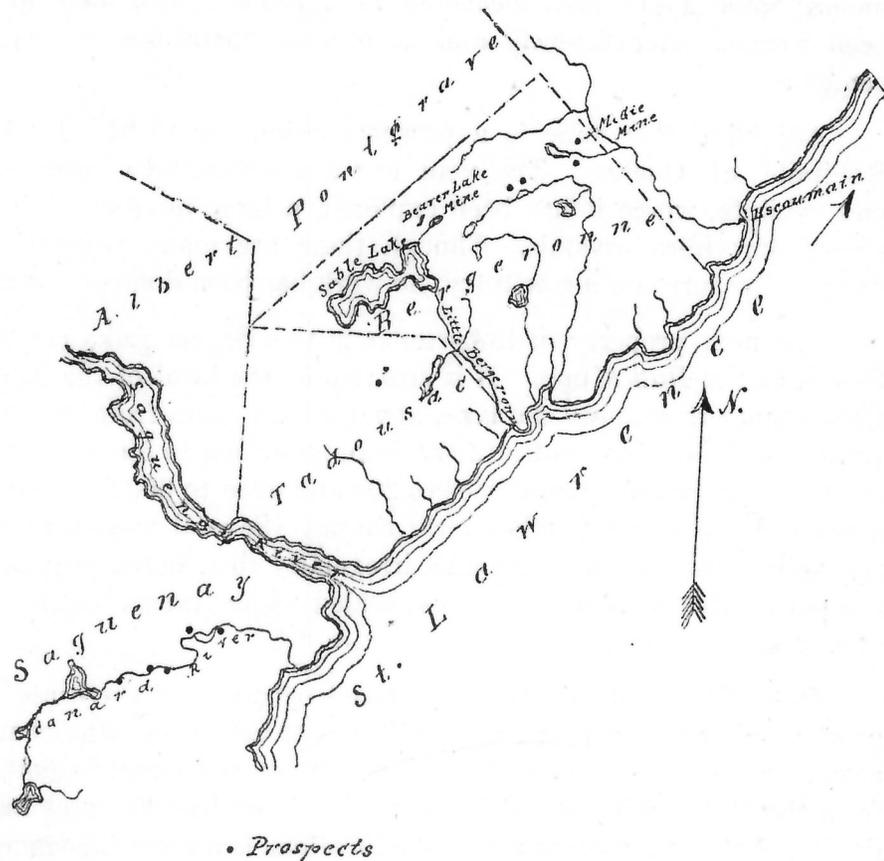

FIG. 9.—Map of the Saguenay Mica Mining District.

The *McGie Mine* is situated in block G, Bergeronnes, twelve miles from Lac des Escoumains. The vein, according to Mr. Obalski's examination, runs northeast for a length of a quarter of a mile, cutting the dioritic gneiss strata. The width is from fifteen to twenty-five feet in the southern part, where the same has been worked for a length of 140 feet. On the northern part the vein measures over seventy-five feet and large crystals can be seen distributed all over the matrix. Two pits, fifteen and twenty-five feet deep, have been sunk. Some of the mica crystals are of large size but break up in small sheets when freed from the rock. Very fine crystals of tourmaline, of garnet and beryl, the last sometimes three inches in diameter, are met with; small quantities of

apatite also are found in the vicinity of the mica crystals. The mica generally is of excellent quality, clear and free from spots and well adapted for ornamental purposes. Fifteen tons of rough mica crystals produced two and a quarter tons of cut mica, 3x4 inches; some larger sizes measured 7x10 inches. The mine has been worked intermittently and at present operations are suspended.

Adjoining this mine is a prospect belonging to Mr. L. A. Robitaille, of Quebec. The vein has a northeasterly direction and exhibits, where it has been explored, a large number of fine transparent mica crystals. Though there are many pegmatite dikes in the surrounding country, no work has been done on them.

The next property of importance is the Beaver Lake claim, known as the *Hall Mines*. It is situated at the head of the little Bergeronnes river, near the lake, about eleven miles from the St. Lawrence river. The width of the vein, according to Mr. Obalski, is 100 feet, increasing sometimes to 200 and even to 300 feet, with a vertical dip and a northeasterly course. Several exposures of the vein show fine mica crystals irregularly distributed through the pegmatite. This property has yielded white transparent mica of exceptional value.

In addition to the above described occurrences there are a great number of prospects, some of them of very promising character. Several veins have been reported in the country north from the McGie mine at the heads of the rivers Beaulieu and Bas de Soie, but the remoteness of these locations is a great hindrance at present to their successful exploitation. Between Tadoussac and Bergeronnes, on the little Bergeronnes river, a dike of pegmatite has been discovered holding large mica crystals on the contact with the gneiss. This vein has been opened up by Messrs. Dupuis and Latimer of Quebec and has given encouraging results.

Along the banks of the Canard river, near the St. Lawrence, a large number of pegmatite veins have been located, but the mica, with one exception, occurs only in small crystals. In this exception a large vein of quartz associated with another vein of pegmatite exhibits an appreciable amount of crystals of fair size. In the Lake St. John region many discoveries have been made, but the transport difficulties are so great that up to the present no serious exploitation has been attempted.

County of Ottawa.

One of the oldest and at one time regarded as the most prominent white mica mine in the country is the *Villeneuve Mine*, in the township of Villeneuve, on lot 30, range 1, twenty miles north of the town of Buckingham and three miles from the Lievre river. In this mine the mineral occurs in a dike of white pegmatite, composed largely of clean white feldspar and quartz; about 150 feet wide, almost parallel to the strike of a reddish and gray quartzose gneiss formation (Fig. 10). The first work on this pro-

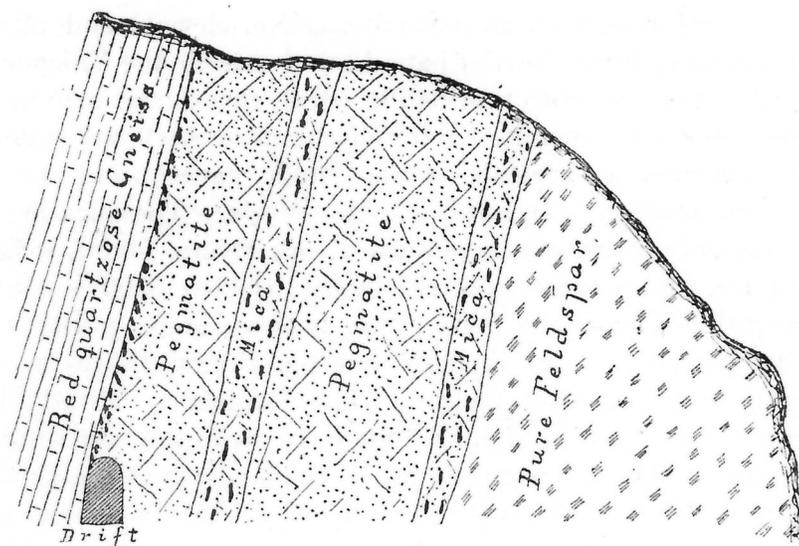

FIG. 10.—Cut through Villeneuve Mine.

perty was done in the summer of 1884 by Mr. W. A. Allan of Ottawa who afterwards sold the mine to the Canadian Mica and Mining Co., Ltd. This company worked steadily from 1884 to 1888 and has produced about 35,000 pounds of cut marketable sheets of excellent quality. The mine, which was well equipped with modern machinery and employed a staff of about twenty-five men, passed in 1888 into the hands of Mr. S. P. Franchot, who worked the mine intermittently from 1890 to 1898. The principal work done on the property consists of a drift started at the foot of a hill along the strike of the vein and near the contact with the

gneiss. This drift has a length of seventy feet, a width of from fifteen to twenty feet and is ten feet high. At this drift a shaft has been sunk sixty feet, following two small fissures or cavities lined with large mica crystals of fine quality.

This mine has come into prominence on account of the minerals containing rare earths which are found throughout the pegmatite dike, but up to this time no serious attempt has been made to extract them. A sample of one of them, uranite, has been analysed by the United States Geological Survey and contained:

Oxide of Uranium	37.7 %
Oxide of Yttrium	2.57%
Oxide of Cerium and Thorium	6.81%

Other minerals such as monazite, cerite, cleveite and pitchblende containing rare earths have been found in the Villeneuve pegmatites, together with tourmaline, beryl, garnet and a number of other accessory minerals. Many of the mica sheets are stained red by tourmaline crystals, while small garnet and zircon crystals are frequently imbedded in the sheets. The mica in the mine frequently occurs in large masses; one crystal found, weighing 281 lbs. and measuring 30x22 inches, yielded \$500 worth of merchantable mica. The feldspar, on account of its purity, has been recognized both in England and the United States as remarkably fit for the manufacture of fine chinaware. Mixed with kaolin in the proportion of 52%, tests have given the best results. In 1889 about 400 tons were shipped to England and to the United States and although the price paid (\$7.00 to \$9.00 a ton) is not very high pure feldspar must be considered a commercial by-product in connection with mica mining.

The following analysis of the feldspar has been made by the United States Geological Survey and, in order to demonstrate the remarkable purity of the mineral, the theoretical composition is added:—

Analysis.		Theoretical Composition.
Silica	63.96	64.61
Alumina	19.16	18.49
Potash	16.88	16.90
Iron.	trace.	

County of Berthier.

The *Maissonneuve Mine*, the property of Theodore Doucet, of Montreal, is situated on the southeast border of Mica Lake, township of Maissonneuve, county of Berthier, forty miles from St. Emilie station on the C.P.R. The rocks on this property belong to the Laurentian gneiss varieties and are cut obliquely by a massive vein of pegmatite varying from 36 to 52 feet in thickness, copiously charged with muscovite in large crystals, many of which yield sheets of merchantable size and quality. This vein has been exposed by an excavation of about twenty feet by twelve feet, averaging ten feet in depth. The vein runs due east and west, while the strike of the gneiss is north 52° west, thus showing that the vein cuts the rocks of the country at an angle of 38° , the dip being perpendicular. A solid, well-defined wall can be seen on the northwest side, on the eastern side the wall has not been laid bare. The vein has been exposed by stripping for a distance of 300 feet and shows the characteristics of a promising deposit. The rock on either side and in contact with it and throughout the country generally is a comparatively fine-grained aggregate of quartz, feldspar and hornblende with scaly particles of mica arranged in parallel layers. The vein matrix, on the other hand, consists of large and coarsely crystalline masses of pure quartz and flesh coloured orthoclase feldspar, confusedly aggregated together, but perfectly distinct from and frequently appearing to penetrate each other with straight radiating cleavage faces for a considerable length. The white muscovite mica occurs in this vein partly in isolated crystals, distributed irregularly over the whole width, and partly in accumulations near the contact with the adjacent formation. All crystals obtained from this mine furnish fine sheets, cutting from 2x3 up to 3x7 inches and some crystals *in situ* measured eighteen inches square.

This pegmatite vein, like that of the Villeneuve mine, is distinguished by the occurrence of foreign minerals. In addition to tourmaline, beryl and garnets the rare mineral samarskite occurs somewhat abundantly in the excavations made in the vein. An analysis of the samarskite found on this property gives the following percentages of the rare earths it contains:—

Oxide of Uranium.....	10.75%
Oxide of Yttrium.....	14.34%
Oxide of Cerium and Thorium	4.78%

Another property which has come into prominence lately on account of the mineral cleveite, containing radium, is situated seventeen miles northeast of the village of Malbaie (Charlevoix county) near Lake Pieds des Monts in the township of Desales. The pegmatite vein has a length of 300 feet and an average width of twenty feet. Some exploration work has been done on this property and a crystal weighing 700 pounds and measuring 32x25 inches, yielding perfect sheets of 10x14 inches, has been extracted. Fifteen to twenty tons of rough mica crystals have been mined and prepared for the market.

PROVINCE OF ONTARIO.

In the province of Ontario several deposits of promise have been discovered, but so far none of them have been worked to any great extent. In the township of Aylwin, about half a mile north of Venosta station, a vein of pegmatite cuts through a grayish garnetiferous gneiss and large crystals yielding excellent sheets are said to have been obtained. In the Parry Sound district, in the township of Proudfoot, a coarse and fine-grained gneiss occurs, containing biotite and gray muscovite mica. The gneiss is penetrated by various masses of fine-grained diorite and by a great number of pegmatite dikes that have attracted the attention of prospectors on account of the beautiful crystals they contain. These dikes vary greatly in size and composition, but even the narrow veins sometimes contain mica crystals of excellent quality. In one of the largest of these dikes the various minerals occur in crystals of gigantic size; microcline crystals attaining a length of three or four feet and mica crystals frequently yielding plates of eight by ten inches. Both biotite and muscovite are found here, but the muscovite, which is perfect in quality and cleavage, is alone suitable for commerce.

PROVINCE OF BRITISH COLUMBIA.

In British Columbia some mica deposits have been exploited in the vicinity of Tête Jaune Cache, about 150 miles northwest of Donald on the C.P.R. According to Mr. McEvoy* the mica occurs as a constituent of coarse pegmatite veins, which cut the country rock, consisting in that locality of garnetiferous mica schists and gneisses, the schists predominating. The pegmatite vein has a width of fifteen feet, sometimes yielding crystals cutting

*Geological Survey of Canada, 1898, Vol. XI.

sheets 18x11 inches. These crystals are generally found on the hanging wall, while some are irregularly distributed through the vein. The mica is a transparent muscovite with a very light greenish tint and appears to be of excellent quality.

There are a number of other deposits of this mica in the same locality and it is possible that this region may produce an appreciable quantity of very fine clear mica which, on account of its high price, will be used for ornamental purposes only. A great drawback, however, to the proper exploitation of these deposits is the lack of access and communication, all supplies requiring to be carried in by pack-trains over trails, which for the greater part of the year are in bad condition.

UNGAVA.

Throughout the archæan rocks of Ungava various pegmatite dikes occur containing large crystals of mica, but owing to the bent and broken nature of the crystals they are seldom of commercial value. A. P. Low* reports the occurrence of "large plates of a light greenish muscovite" on the Eastmain river, between the Talking and Island falls, and mentions the occurrence of fine crystals in a red pegmatite dike near the head of Lake Winokapau.

Phlogopite.

HISTORY.

Canada has long been known to be rich in economic phlogopite deposits. More than forty years ago Sir William Logan** referred to the phlogopite deposits of Grenville, Quebec, and in North and South Burgess, Ontario, "in all of which" says Sir William "the mica is obtained in large sheets which, being transparent and free from flaws, are wrought and employed for the same purposes as the muscovite or potash varieties. A crystal from Grenville was so large as to furnish sheets measuring twenty-four by fourteen inches. Good mica, we are told, was found on the 10th lot of the 5th range and on the 1st lot of the 10th range of Grenville, as well as further to the westward of this township. On the 17th lot of the 9th concession of the township of North Burgess large crystals of magnesian mica were found in abundance in a bed of pyroxenic

*Geological Survey of Canada, Vol. VIII.

**Geology of Canada, 1863, pp. 494 and 795.

rock. The mica was traced for about 300 feet and considerable quantities were extracted. It appears probable that in this region and in Grenville sufficient quantities of mica could be obtained to supply a large demand."

The Sydenham Mica Mining Company in the Kingston district was one of the earliest producers of phlogopite. Prior to 1890 large quantities of mica were raised in connection with phosphate mining in the district round Perkins Mills, Quebec. During the extensive operations in the phosphate mines of the Ottawa county mica was more or less a dominant factor in the mineral raised, occurring in some cases in such quantities that the quality of the apatite was seriously impaired. Mica being at that time unmarketable, for it was only in the year 1890 that the demand for this particular mineral commenced, it was thrown into the dump as useless, but the experience gained during the phosphate mining as to the mode of occurrence was turned to account when mica became a commercial commodity. Many phosphate mines were worked both for mica and for phosphate, but it was found that the peculiar character of the mica deposits did not admit of mining profitably the two minerals at the same time. Apatite mines gradually turned into mica mines, the apatite being mined only when in the immediate vicinity of the mica,

GEOGRAPHICAL DISTRIBUTION.

The occurrence of workable phlogopite deposits appears to be confined solely to Canada and more especially to an area of 520 square miles included in the country north of Ottawa, province of Quebec, and in the townships of Burgess, Lanark, and Loughborough, province of Ontario.

An examination of the accompanying map shows that the country north of Ottawa comprises the largest mica field. Apart from some occurrences in the townships of Orthfield and Blake, this mica producing country covers a triangular area of about 400 square miles, with the southwestern corner north of the city of Hull, the northeastern in the southern part of the township of Derry, and the northern corner in the northern part of Hincks.

There are two separate mica districts in the province of Ontario; one, of approximately seventy square miles, is situated in the townships of Loughborough and Bedford, with the village of Sydenham as mining centre; the other, of about fifty square miles, is located in North Burgess, with the town of Perth as centre.

TOPOGRAPHICAL FEATURES OF THE MICA FIELDS.

The southern portion of the productive mica area of Ottawa county is characterized by large stretches of flat farming land, here and there interrupted by low, long ridges, generally covered with bushes and underwood. The whole northern part, however, with few exceptions, is a series of low rounded hills and ridges of gneissic rock, grouped together without any marked regularity and denuded, for the most part, of vegetation. These hills strike sometimes as chain-like eminences through the country, forming small stretches of agricultural land in the valleys. Their height varies from one to several hundred feet above the general level of the country, but none can be described as mountains although often locally so called.

The country, as a whole, is traversed by numerous little creeks and rivers which empty into or drain a number of lakes. Most of these rivers, owing to the rugged nature of the district, contain rapids and descents which can be utilised as sources of power for mining purposes. A fine example of this is twenty-five miles from Buckingham, on the Lievre river at the High falls, where there is a clear descent of 130 feet, and another fall of twenty feet at the Little rapids is eleven miles from the same town. A lock and dam have been built at the latter rapids, enabling steamers to ply between Buckingham and the High falls. Another example is on the Blanche river, in the township of Templeton, where there are three steep descents between Lake McGregor and its confluence with the Ottawa river.

The timber limits of these districts have been vigorously worked in former years and owing to this cause and the extensive bush fires which swept over the country none of the original forests are preserved. However there is, nearly everywhere, a good supply of second growth of timber available for mining purposes.

Transportation facilities are satisfactory, although on account of the hilly nature of the country the roads have often winding and erratic courses. They are for the greater part of the year in good condition, while the Ottawa, Northern and Western Railway and the navigable lower part of the Lievre river tap most of the productive mica field in the north. It is evident, then, that the district is splendidly adapted for mining operations and, on account of its settled condition, little difficulty is experienced in procuring labour.

The general character of the country round Sydenham and

Perth is somewhat different. While there are many lakes and rivers traversing the country in a northern direction and affording splendid transportation facilities, the country, as a whole, consists of low rock lands, occasionally interrupted by small gneissic ridges, covered, as a rule, with a second growth of timber. The intervening stretches, consisting of low lying swamps, are used for agricultural purposes and throughout the district farms and settlements are numerous. Timber for mining purposes is not plentiful but can be obtained at a cost of from four to five dollars a cord.

GEOLOGICAL OCCURRENCE.

The occurrence of workable phlogopite deposits is confined solely to the great Laurentian formation, which consists, in the mica-bearing areas, of the following typical rocks:—

- 1.—Red, gray and white orthoclase gneiss in great variety, distinctly banded.
- 2.—Black hornblende and mica gneiss, often garnetiferous and cut by veins of white and red oligoclase.
- 3.—Pyroxenic gneiss, banded.
- 4.—Large bands of crystalline limestone.

These rocks are distinctly stratified and dip generally at all angles, from almost horizontal to vertical.

The southern extremity of this formation is in the township of Loughborough, in the country around the village of Sydenham, the centre of the mica industry for southern Ontario. The Laurentian formation then extends in a northerly direction through the townships of Bedford, Crosby and South Sherbrooke into the township of North Burgess and here again we find another extensive mica district south of the town of Perth. Between this town and the city of Ottawa the Laurentian formation is overlaid by Cambro Silurian rocks, hence this area is not mica bearing. North of the city of Ottawa and the Ottawa river, in the county of Ottawa, province of Quebec, the Laurentian formation again outcrops and covers practically the whole area northward. In the country tributary to the Lievre and Gatineau rivers we find the most productive mica belt, which now appears to be the backbone of the Canadian mica industry.

The horizon of mica deposits is confined to the upper portions of the Laurentian siliceous rocks which underlie the limestone

proper.* These gneisses are generally of gray or reddish gray appearance with hornblendic bands, nearly all of which are highly siliceous. These beds penetrate through the calcareous layers into the massive crystalline limestone formation. In the Buckingham and Templeton areas apatite and mica are seldom found in the crystalline limestone, but in the Gatineau area several large dikes of pyroxene occur in this formation, carrying workable mica deposits. (Fig. 11).

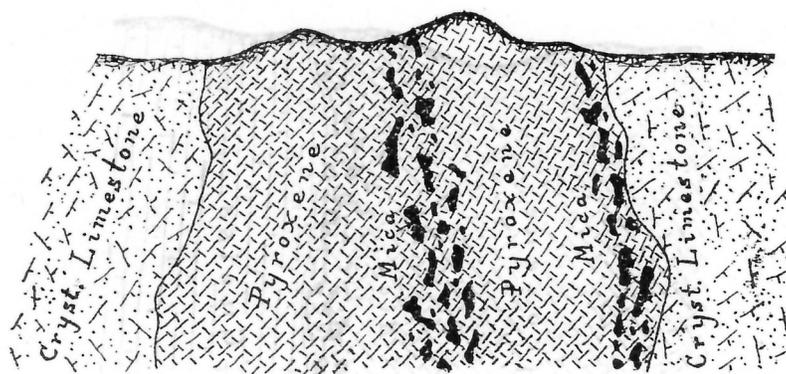

FIG. 11.—Pyroxene Dike in Crystalline Limestone.

The deposits of phlogopite mica are associated with pyroxene, which penetrates the gneiss or limestone in the form of dikes. Sometimes these dikes occur along the banding of the country rock and extend in lenticular masses along the planes of stratification. This mode of occurrence of the pyroxene has, presumably, led to the early supposition that these rocks were also an integral part of the altered sedimentary rocks of the Laurentian formation. In most cases, however, the pyroxene dikes cut across the stratification of the gneiss and associated strata and penetrate these rocks at all angles like dioritic dikes, thus furnishing conclusive evidence of their intrusive character. This is also recognized in the many openings that have been made in the apatite and mica deposits in the Gatineau and Lievre districts and also in several deposits near Perth.

In many cases the gneiss has no distinct lines of separation from the pyroxene, but seems to have been penetrated with small branches or spurs of this rock, forming, near the contact, a more or less pyroxenic gneiss which is easily decomposed and eroded by

*Dr. Ellis. "Mica Deposits of the Ottawa District," Geological Society of America, 1894.

weathering. Mica deposits of highly irregular character are frequently found filling up the gap between two spurs, but, on account of the great decomposition the crystals have undergone, yield, as a rule, very little commercial mica.

Generally two classes of deposits can be distinguished:—

- 1.—Contact deposits, forming the contact between the gneiss and pyroxene (Fig. 12).

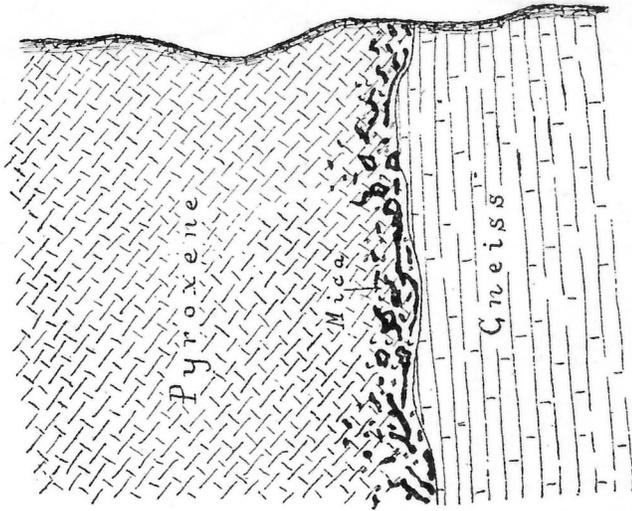

FIG. 12.—Contact Deposit.

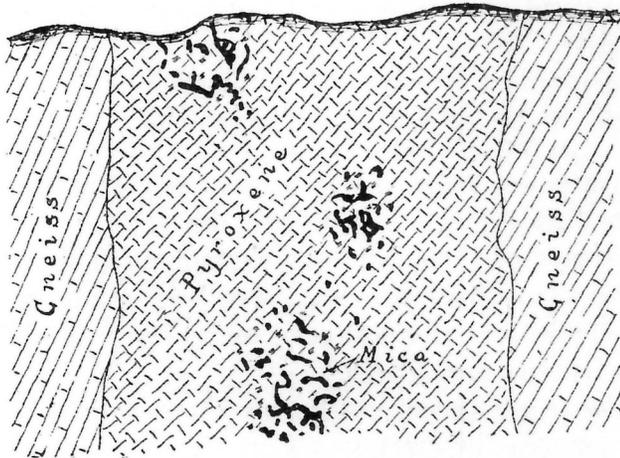

FIG. 13.—Pocket Deposit.

- 2.—Pocket deposits, occurring in fissures wholly in pyroxene (Fig. 13) or on the contact between intrusive feldspar or diorite and pyroxene.

They occur in the form of single crystals scattered through the mass of the dike in irregular pockets, lenticular bodies, little bunches, bands and, in the case of contact deposits, in vein-like accumulations.

All deposits are composed more or less of micaceous matter (namely, numerous scaly particles grouped together in a compact mass) and small or large mica crystals of possible commercial value. In the majority of cases they also contain small bunches or pockets of calcite of a reddish pink colour, or they are accompanied by small bands or massive bodies of the same mineral.

Mica crystals found in calcite are, as a rule, well formed and deliver a large percentage of good sheets; intergrowths of crystals in calcite are rare and the "ribbon mica" is less frequent. Apatite is frequently met with in small masses in the vicinity of mica deposits, while crystals of the same mineral are found imbedded in the calcite or pyroxene or are intergrown with mica. In some cases the latter penetrate the apatite and inclusions of calcite or apatite in the form of plates and crystals are found in the centre of a mica crystal. Mica crystals imbedded in pyroxene have seldom a perfect crystalline structure.

CONTACT DEPOSITS.

The vein-like or contact deposits are the most important from a mining point of view. As a rule, the mica occurs in lenticular bodies connected with each other along the solid wall of the gneiss formation, or along certain well defined lines of fracture, in vertical as well as in horizontal extension.

These vein-like deposits frequently send out spurs or branches into the mass of pyroxene, while cavities filled with well defined crystals are often met with along the wall of the adjacent formation. Calcite is a usual accompaniment of the mica and in the majority of cases is deposited near the solid wall of the country rock. The presence of this mineral, on account of its generally containing mica crystals of nearly always perfect quality, is looked upon with favour by miners.

A great advantage in the mining of vein-like or contact deposits lies in the fact that the amount of dead rock to be removed is reduced to a minimum, while development work can be pursued more systematically.

The following mines are good examples of the contact type: the Wallingford mine at Perkins Mills, P.Q., Figs. 14 and 15; the Kodak mine of the late Wakefield Mica Company on lot 16, second range of the township of Wakefield, Fig. 16; the Battle Lake mine, Fig. 17; and the Rheame Lake mine, in the township of Templeton Fig. 18; the Baby mine, in North Burgess, Ontario, Fig. 19, and the Lake Girard mine, Fig. 20. Most of these deposits have been worked downward, along the contact with the gneiss, for over 200 feet, as at the Lake Girard.

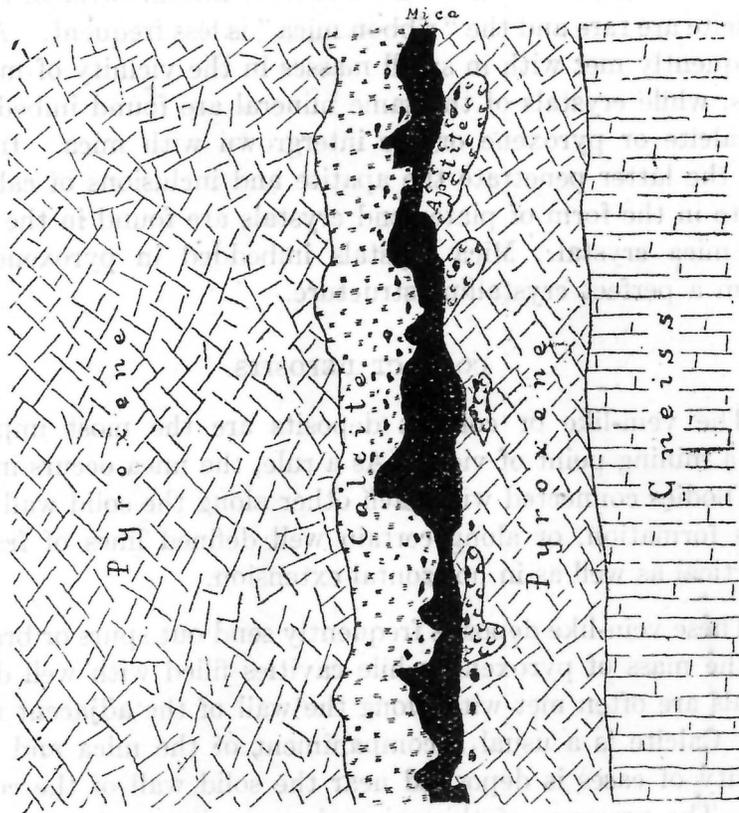

FIG. 14.—Section of Mica Vein in Wallingford Mine.

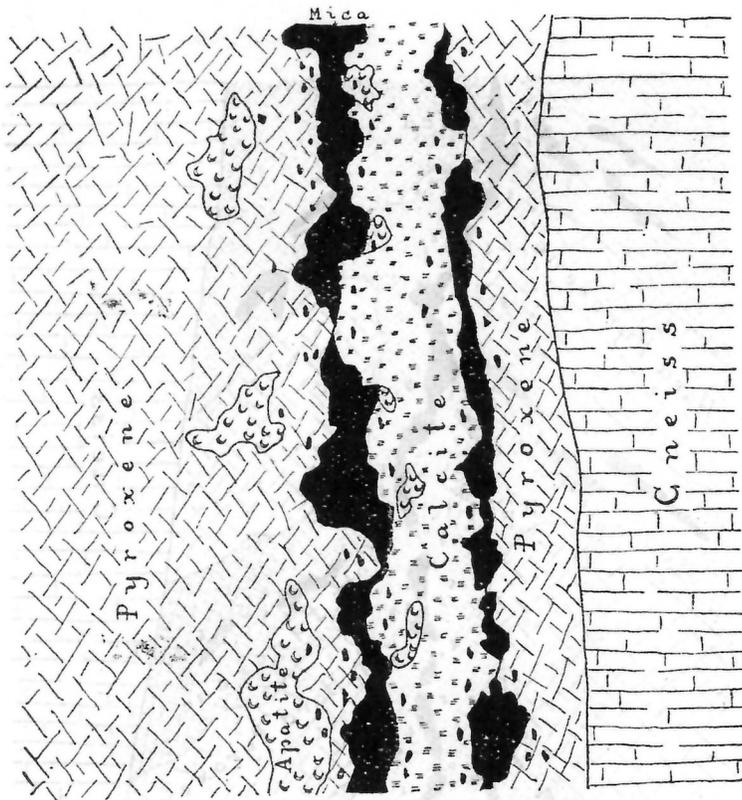

FIG. 15.—Section of Mica Vein in Wallingford Mine.

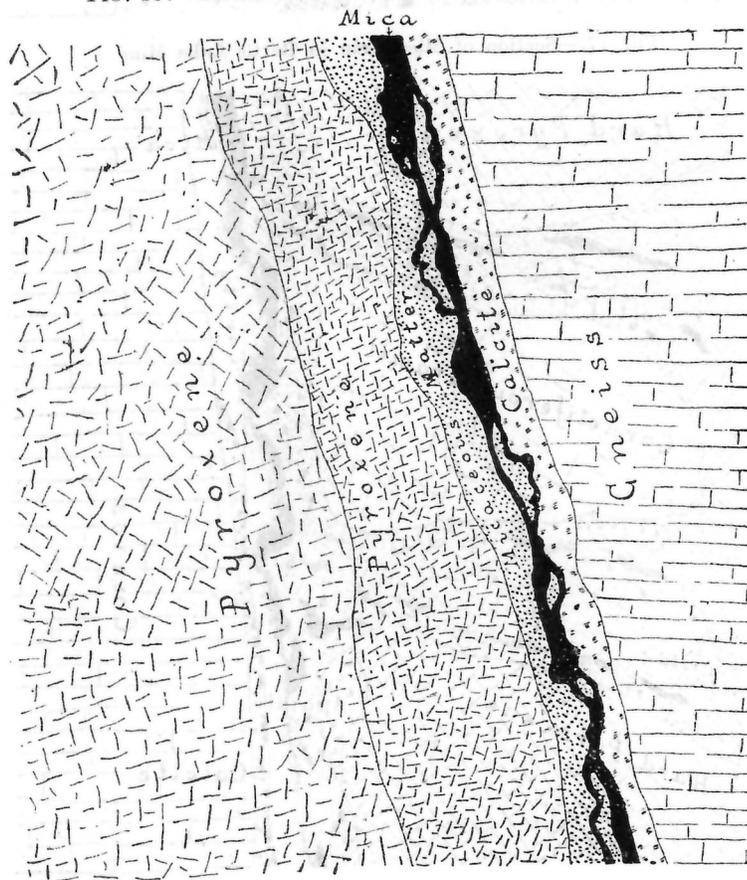

FIG. 16.—Section of Mica Vein in Kodak Mine.

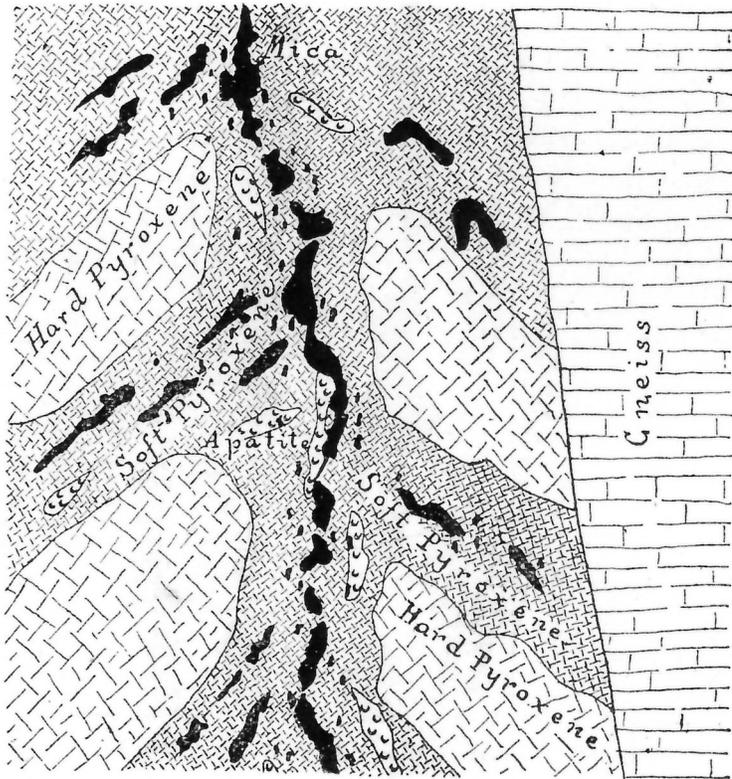

FIG. 17.—Section of Mica Vein in Battle Lake Mine.

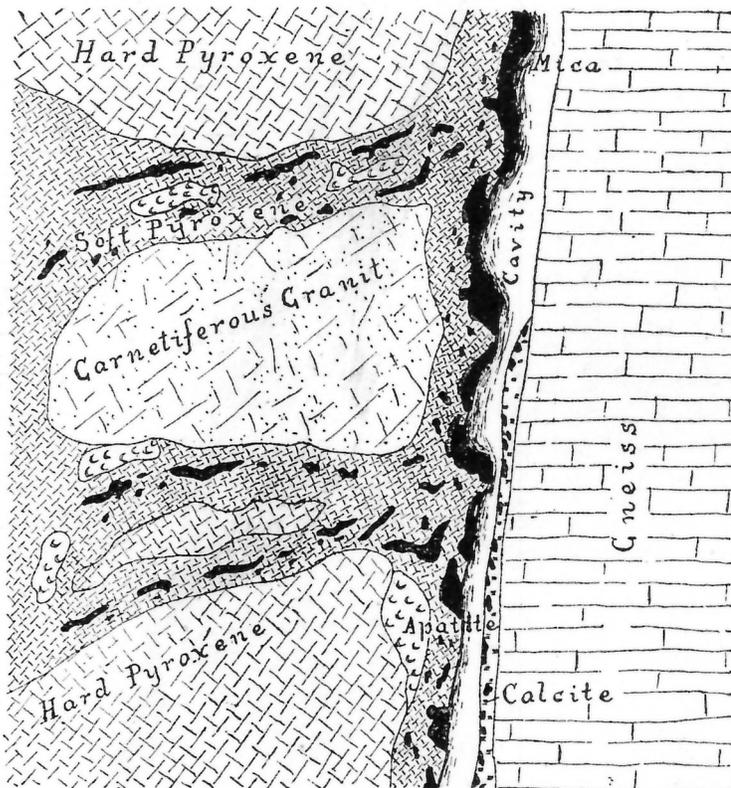

FIG. 18.—Section of Mica Vein in Rheame Lake Mine.

It is frequently observed, especially near the contact with feldspathic, gneissic rocks, that the pyroxene holds boulders of a dark feldspar mixed with quartz, sometimes merging into a massive granite, and that between these boulders mica crystals are imbedded in a matrix of a soft and pale green pyroxene, giving to the whole a cobwebby appearance. An example of this kind is the Battle Lake mine, township of Templeton (Fig. 17) and the Rheame Lake mine in the gore of Templeton (Fig. 18).

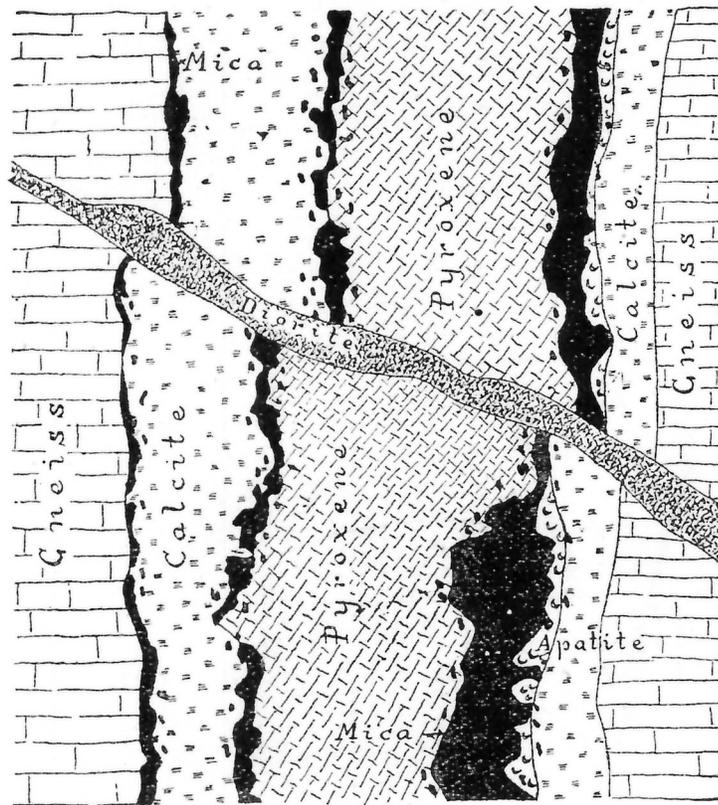

FIG. 19.—Section of Mica Vein in Baby Mine.

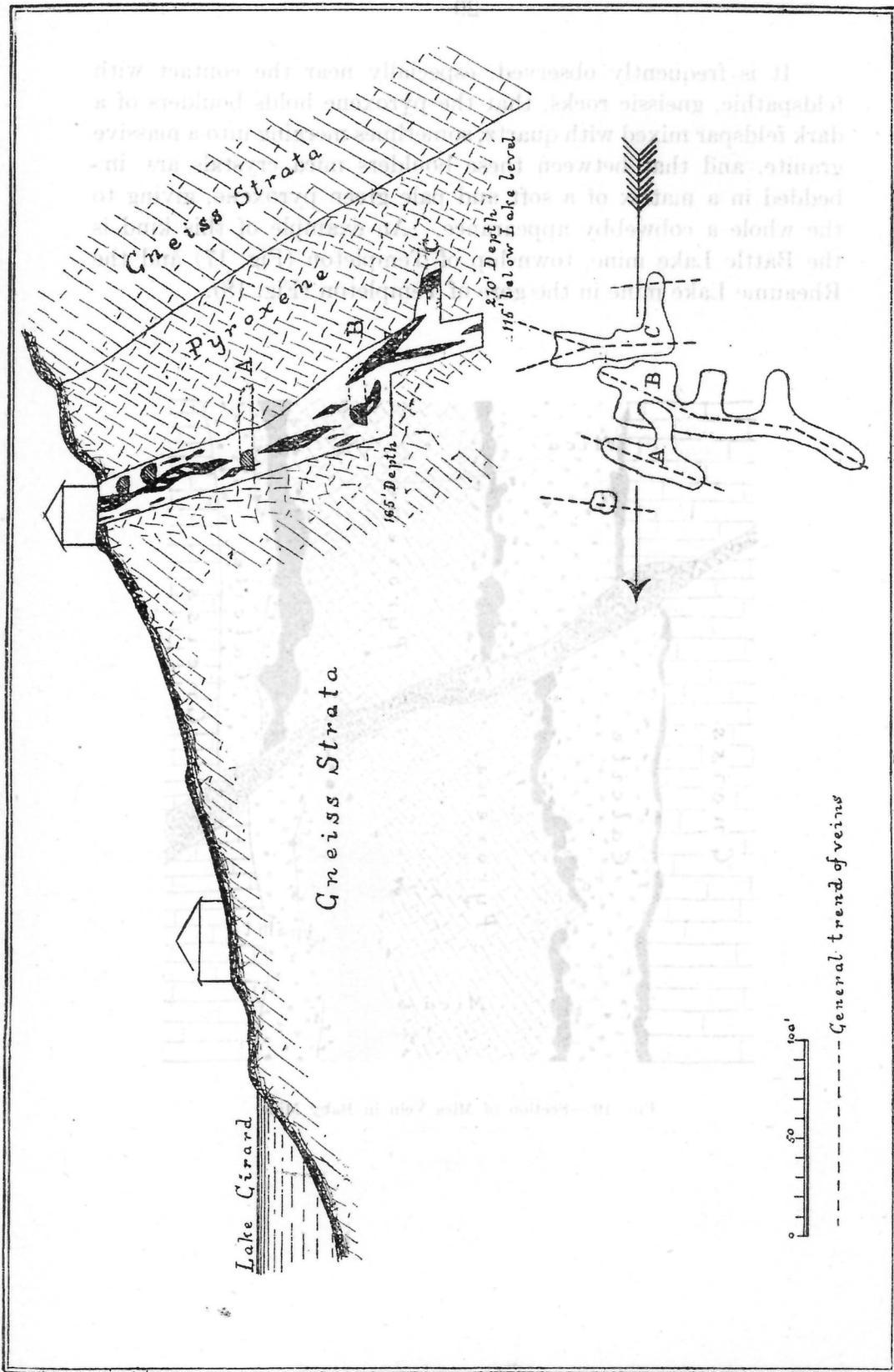

Fig. 20.—Cut Through Workings of the Lake Girard Mine.

POCKET DEPOSITS.

As to the second mode of occurrence, that is, pockets near small dikes of diorite and feldspar, or wholly in pyroxene, it must be stated that although some good mines of this class, including several properties at the Cascades on the Gatineau river, have been discovered and have yielded a large output, their mode of occurrence gives rise to greater uncertainty as to their permanency and entails more risk as to their working than that of the vein-like deposits. Many mines of this class contain splendid deposits of large size. The general occurrence resembles a chain of lenticular bodies, extending in depth as well as horizontally, but the dead rock and the absence of any leading indications between the deposits render their location very difficult to ascertain and this is the main reason why we hear so much of a mica mine giving out. It is also the reason why the underground workings of a mica mine belonging to this class are of such an irregularly shaped character and so little resemble the methodic work seen in lode mining. The mica generally follows certain lines of faults or fracture, forming occasionally stringers or narrow veins, splitting up or converging into each other. Cavities are frequently met with, sometimes of very large dimensions, lined with mica crystals or crystals of pyroxene and apatite. The quality of the mica found in the cavities is generally very fine, owing to the fact that the crystals seldom show a lateral disturbance in their foliation and possess all the necessary properties for a commercial product.

In many cases we find that a very small percentage of useful mica is contained in the deposit, the greater part of which is made up of shattered, contorted and twisted mica crystals, or sometimes of micaceous rock matter. This condition was apparently brought about by disturbing influences, either by the shifting of the adjacent formation or by a sudden change in temperature during the process of the formation of these crystals out of the heated magma which filled the fissures from below.

THE OCCURRENCE OF APATITE IN CONNECTION WITH MICA.

As regards the occurrence of apatite in association with mica we can discriminate in a general way between three different areas in the country north of Ottawa, namely:—

- 1.—The Lievre district.
- 2.—The Templeton district.
- 3.—The Gatineau district.

In the Lievre district, that is, in the country north of Buckingham, most of the phosphate mines contain very large apatite deposits to a depth of over 1,000 feet (as at the High Rock and North Star mines), while mica in connection with this mineral is occasionally met with. Generally, when mica is associated with apatite the crystals are brittle and contorted and break up into small pieces, the quality of the apatite, on account of these impurities being seriously impaired. In the Templeton district and more especially in the pyroxene belt around McGregor lake where mica is found freely associated with apatite the crystals met with are perfect and in sound condition. In the *Phosphate King Mine* near Perkins Mills very fine crystals measuring more than eighteen inches across the basal planes were found in solid apatite, and at the *Wallingford Mine*, in the immediate vicinity, the mica in association with apatite is equal to the best the mine produces. Another example is the *Blackburn Mine*, where large masses of clean high-grade apatite are occasionally seen in association with mica deposits of considerable extent. The occurrence of a pink calcite is one of the characteristics in connection with this association in the Templeton area, the calcite very often replacing the apatite and carrying good mica crystals of commercial value.

The Gatineau district is distinguished from the other districts by carrying a larger amount of calcite in the pyroxene. The pyroxene may, in connection with mica, occasionally contain larger crystals of apatite and sometimes small pockets, but it is seldom that this mineral can be profitably worked. With one or two exceptions, this district affords little encouragement for the profitable mining of apatite in connection with mica.

Mica deposits are frequently cut off by apatite. An illustration of this kind is found in the *Phosphate King Mine* in Templeton (Fig. 21). A vein-like accumulation of mica of a width of three

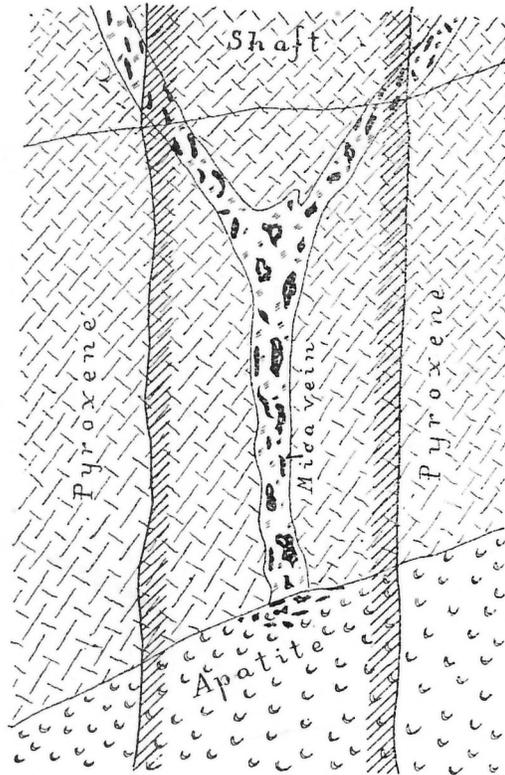

FIG. 21.—Mica Vein cut off by Apatite.

feet was followed down to twenty-six feet. At this depth a large high-grade apatite deposit cut off the course of the vein. A few perfect crystals of mica were found scattered through the apatite and when this body was penetrated the original mica deposit continued on the other side in its regular downward course.

THE ONTARIO SECTION OF THE MICA FIELD.

The deposits in the Sydenham and Perth mica districts bear a great resemblance to those of the Templeton district and most of the remarks relating to the one are applicable to the other. It appears, however, that the pyroxene dikes and consequently the mica deposits in the Ontario section are not so abundant as in the

country north of Ottawa, in which region the pyroxene dikes, divided only by narrow intervals of country rock, are grouped into one productive field. In the Sydenham and Perth section, on the other hand, there are extensive, intervening stretches of country rock, accounting for the discoveries recorded in a given area of this region being less numerous than in a similar area of the Quebec division.

MICA OUTCROPS.

On account of the great irregularity and variation of occurrence and the superficial character of many of the outcrops, surface indications are not sufficient data from which to deduce the value of mica deposits. All outcrops must be explored to depth before any definite idea can be gained as to their extent and quality.

In many cases, especially on mountain slopes and small ravines, we find that the humus covering the solid rock contains a considerable amount of mica sheets of fine laminae and much money has been spent in the frequently fruitless effort to find the

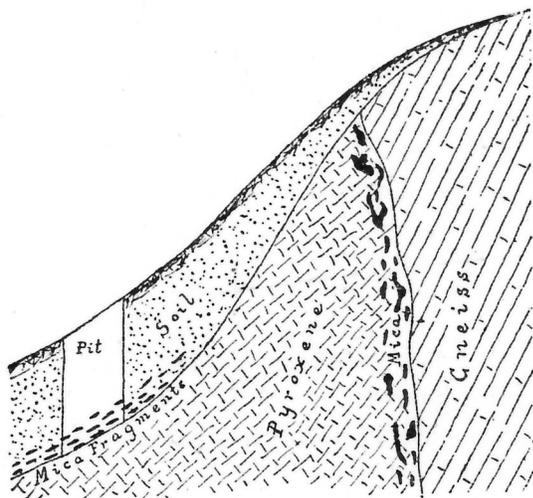

FIG. 22.—Displacement of Mica in Soil.

mica in the solid formation. This failure is due to the weathering and decomposing process of nature; all crystals on the surface undergo decomposition; the sheets are loosened, separated, split up in fine laminae and all, or part of them, are carried away by the action of water and deposited in places lower than the outcrop from whence they came and sometimes far away. (Fig. 22). Thus it happens that we have an apparently large deposit of sheet

mica and decomposed crystals in the soil, while we find nothing in the underlying rock.

In examining a mica property the inexperienced prospector is deceived by this sporadical occurrence of mica and concludes that the property he is examining is a very desirable one, whereas it very likely contains deposits of little or no value.

ORIGIN OF MICA DEPOSITS.

Concerning the origin of Mica (Phlogopite) Deposits, the latter are so intimately associated with pyroxene and apatite that we may consider them analogous and that which can be said for these rocks to some extent is applicable also to mica. In the case of the Canadian apatite deposits the eruptive or igneous origin is well recognized.

Most of the pyroxene analysed contains a considerable amount of calcium and since it must have ascended along lines of fracture or least resistance in its intrusion, it may be reasonably inferred that vapours charged with phosphoric acid ascended along such lines rather than through the compact rock mass. These vapours impregnated the softened or heated magma in certain portions in proximity to the margins of the pyroxene masses and as a result of the chemical action upon the calcareous portion the phosphate of lime or apatite was produced.

As to the mica, its formation would seem to indicate a crystallization from an aqueo-igneous solution along lines of fractures in certain portions of the pyroxene, in conjunction with the formation of apatite. This is rendered the more probable by the occurrence of thin sheets of calcite between sheets of mica and by the impression of the mica sheets on fragments of well crystallized calcite, forming a sort of tapered cone with microscopic steps. So far this latter phenomenon has not been observed on the feldspar, though thin sheets of this also have been found between sheets of mica.

The impression of the edges of mica sheets upon calcite would seem to indicate that the mica crystallized first out of the injected magma, and in so doing inclosed at times apatite or calcite between the layers, and at other times but not so frequent feldspar.

In nearly all the mica deposits we can observe that the pyroxene is the earlier formed and the phlogopite the later formed mineral. In some deposits the two form a regular net work the interspaces of which are either empty or filled with a coarse grained

aggregate of reddish coloured calcite or apatite. From the foregoing it is evident that the sequence of the four vein minerals is thus: pyroxene, phlogopite, apatite, calcite.

Although the enclosing rocks offered considerable resistance to the fissure force, still after the entrance of the vein matter, in some fissures it was free to crystallize in large pure masses, as can be noticed in some of the more prominent mica mines in Templeton. Where the aqueous solution was over-saturated the free crystallization was considerably impaired and the consequent result was the formation of a contorted and twisted mica. The brittleness of some of the mica is very likely due to the sudden cooling off of the crystals by some causes during the process of their formation.

In addition to these phenomena a shearing force would seem to have acted at times. Some blocks of mica are cut through and thin filaments of mica left adhering to the edges. This may have been caused by a slow slipping along a fold, as the edges do not exhibit the appearance usually caused by cutting or shearing with heavy instruments.

Considering the foregoing data, we must come to the conclusion that the apatite and mica deposits in the Archæan rocks are the result of emanations and injections of varied kinds of igneous rocks which have accompanied or immediately followed the intrusions of pyroxenic masses.

That these masses of pyroxene are deep-seated is seen at the High Rock and North Star workings, where vertical depths of 1,100 and 900 feet respectively were attained. In both these mines, which represent the deepest Canadian workings in pyroxene rock, the prospects for successful mining of apatite are as satisfactory at the bottom as at the surface. The conditions under which the pyroxene occurs in Templeton and in all the other districts are almost identical with those of the Lievre river and consequently the experience gained in the deep phosphate mines can be justly applied to the mica mines of the productive area.

The intrusive character of the pyroxene, as illustrated above, is another reason why we may disregard the contention of many operators of mica mines that the deposits are only of superficial character.

From the foregoing it may reasonably be inferred that the mining of mica in depth is limited, not by nature, but by market conditions and the increased cost of mining.

CHEMICAL COMPOSITION OF PHLOGOPITE MICA.

The following table gives the chemical compositions of some of the Canadian species taken from several localities:—

	*Mica from North Burgess.	**Mica from Templeton.	**Mica from Perth, (Lacey)	*Mica from Lievre River.
Silica.	40.97	40.00	39.66	39.5
Alumina	18.56	17.00	17.00	16.5
Magnesia	25.80	26.50	26.49	22.00
Potash.	8.26	10.00	9.97	—
Soda	1.08	—	0.60	—
Iron.	—	0.50	0.47	8.5
Volatile.	1.00	3.00	2.09	4.00

It would appear from the above table that as far as the contents of iron is concerned the mica from North Burgess is the purest, the mica from Templeton and Perth comes next, while the sample from the Lievre river shows eight and a half per cent., which excludes its use for insulation purposes.

*The Geology of Canada, 1863, page 495.

**From private sources.

CHAPTER III.

THE MINING AND PREPARATION OF MICA.

The Mining of Mica.

The work of extracting the mica from the rock and converting it into a saleable article is divided first into the ordinary mining operations, such as drilling, blasting and hoisting, together with the collection and transport of the mica to the cobbing sheds, and, second, the dressing or cobbing, that is, the separating of the mica sheets from the adhering rock particles and grading of those sheets into different sizes and qualities which are packed for transport.

It is of importance to review these different operations, involving, as they do, the entire cost of the production of mica. The success of any mine depends to a large extent upon the careful, economic and intelligent management of the different branches, but this applies more especially to the mining of mica, which is carried on under conditions so widely different from any other mining, especially lode mining.

MINING METHODS.

On account of the irregular character of most of the mica deposits, the methods employed to work a mine are manifold. The easiest work and the one which requires little or no systematic preparation is the open quarry—where several deposits or pockets are mined together until the rock *in situ* shows no more mica. The disadvantages of this method are obvious: on account of the severe weather, no efficient work can be performed during the winter, while in many cases, where the deposits are not rich, the hoisting or removing of so much dead material is a cause of great expense.

Working underground has, therefore, many advantages, the principal one being the possibility of continuous operations. In the case of a vein-like deposit, with defined walls, a shaft is usually sunk on the foot wall and the deposit opened up at intervals of thirty to fifty feet by side drifts and subsequently by rises and winzes. The mica so laid open is then stoped whenever desired. Occasionally pillars are left supporting the walls and roofs in the drifts.

In the case of pocket deposits which consist of irregular dis-

connected bodies dispersed through the formation no methods such as these can be employed. Generally an inclined central shaft for the hoisting of all material is put down in the surface deposit and all the mica in sight is taken out. Then the shaft is continued, drifts are run in all directions in the hope of finding other deposits and this system is continued until no more mica can be found in the neighbourhood of the shaft.

This mode of working has one great disadvantage, no large stopes of mica can be blocked out and, consequently, the mine is a mine without reserves and can never be prepared for a future regular output.

THE WINNING OF MICA.

As to the mining proper it must be remembered that the peculiar properties of mica do not permit of the quick work suitable to any other mining. In large mines of any other description hand drilling, for instance, is replaced almost entirely by machine drilling, but this practice cannot be generally followed in the case of mica mining. The peculiar location of the crystals, either single or in accumulations, in the rock matrix makes a certain position of the drill holes imperative if the fine sheets are to be unimpaired and, as a rule, this position cannot be attained by machine drills. Hand drilling, therefore, is not only the rule when blasting is to take place near the deposits, but the holes so drilled are only lightly loaded, the object being just to loosen the rock preparatory to taking it down with the mica by picking, or, in the case of very valuable crystals, with hammer and chisel. This slow advance, however, is well repaid by the results so obtained and the greatest attention should be paid to the winning of well preserved crystals in this careful manner.

EFFECT AND COST OF HAND DRILLING.

Hand drilling is generally performed by three men on each hole, two striking and one turning. Employing one-inch octagon steel and hammers weighing six to seven pounds, the three men should average, in hard pyroxene, from fifteen to twenty feet a day of ten hours, at a cost of from eighteen to twenty-two cents per foot. The depth of the holes seldom exceeds four feet. Single handed drilling—where the operator uses steel three-quarters of an inch thick—has been noticed only in one of the Wakefield properties.

EFFECT AND COST OF MACHINE DRILLING.

In the larger mines drilling in development work is done with steam or compressed air. When steam is employed, one drill averages from thirty-five to forty feet per day; in the case of compressed air, the average is about five feet more. The cost per foot, dependent on the cost of fuel in the district, ranges between eight and ten cents, not including wear and tear of machinery.

The employment of steam for drilling below a certain depth has great disadvantages, the principal one being the great dampness and inconvenience caused by the steam lingering in the levels. This impedes ventilation, more especially after the firing of shots.

COST OF BLASTING.

The blasting is now generally done with dynamite, containing 35% nitro-glycerine and costing from sixteen to eighteen cents a pound. In three of the larger mines the firing of shots is performed by electricity, all the other mines, however, blast by means of fuse and caps. While the latter practice is more or less dangerous, it has advantages over blasting by electricity, inasmuch as the firing of the single holes in succession can be easily regulated, the quantity of dynamite used is reduced to a minimum and the crystals are less broken and scattered. The cost of blasting in mines where hard pyroxene occurs in boulders and where the drifts are wide and roomy (that is, over seven feet wide and of corresponding height) is, approximately, from five to seven cents per ton of rock broken. In open quarry work this cost should not exceed four cents per ton.

REMOVAL OF DEBRIS.

The next operation is the removal of the broken rock from the pits to the dump and, simultaneously, the picking up of the mica crystals and sheets.

In the case of an open quarry, if the bottom of the latter is on the same level with the top of the dump, the removal of the debris, etc., is very simple; it is loaded on small dumping cars and brought to the dumping ground or to the cobbing shed. But in the case of deep mining the rock has to be hoisted by means of derricks or solid gallow frames and buckets. Hand and horse derricks are employed only in small mines; all the larger mines employ steam power in connection with hoisting. Excepting one mine in the Quebec division which uses cable derricks, all the mines employ the boom type.

A boom derrick (Fig. 23) consists, in the main parts, of a mast (a) and a boom (c). Mast (a) is turnable on its own axis and is held in vertical position by means of guy ropes (b) or so called "stiff legs." Boom (c) is held in a suspended position by rope (d) and pulley (f) and can be lowered and raised at will. The bucket is attached to pulley (g). The length of the boom is from thirty to fifty feet, its working radius is naturally limited and can hardly be extended more than fifty feet.

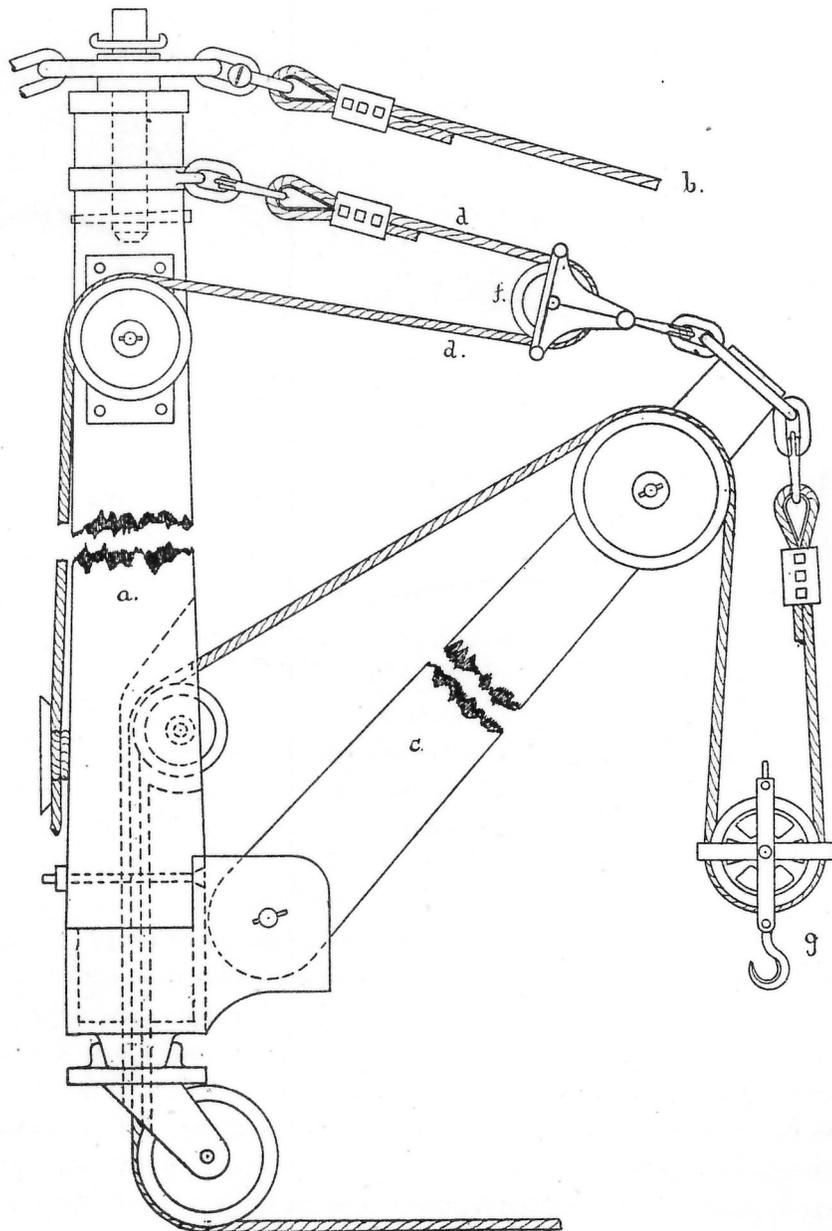

FIG. 23.—Boom Derrick.

CONSTRUCTION OF CABLE DERRICKS.

The construction of the cable derricks is based upon the same principle as the boom derricks, but instead of a boom there is a cable with a carrier on it. This cable is stretched from the top of a solid mast to some point across the working pit, so that hoisting can be performed from any point vertically, or nearly verti-

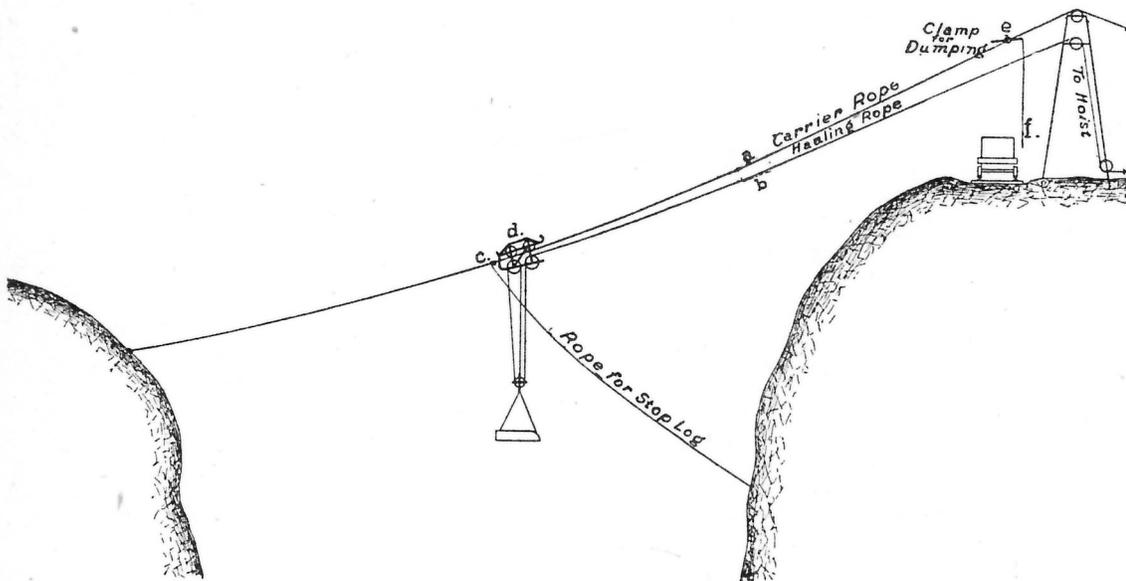

FIG. 24.—Incline Cable Hoisting Shaft.

cally below the cable. These cables can be stretched 400 feet; they have a diameter of $1\frac{1}{2}$, $1\frac{3}{4}$ and 2 inches and are made of crucible cast steel. The ropes used for hoisting are $\frac{5}{8}$ and $\frac{3}{4}$ inches in diameter, similar to those used in boom derricks.

In their simplest form, these incline cableways (Figs. 24 and 25) consist of a carrier (d) and two wire ropes, one the carrier rope (a) stretched between an A-frame and some well guyed point across the pit and on which rope the carrier runs; the other the lifting, or as it is usually called, the fall rope (b), which in this type also serves as a hauling rope. In order to provide sufficient resistance to cause the load to be lifted before the carriage commences to travel along the carrier it is necessary that the cable

be inclined so that the loaded carriage moves upward to a stop (e) on the carrier rope situated above the dumping point. To insure satisfactory working, the inclination required is seldom less than 30° . On stopping the carriage at any point on its upward journey, the load may be lowered and dumped, after which the carriage returns down the incline to the stop (e). It is generally necessary, however, to provide a bridle or link (e), pivoted to a wooden clamp on the carrier rope over the dumping point, which link is raised by a cord (f) and dropped over the hook on the end of the carriage before dumping and afterwards released to allow the carriage to return.

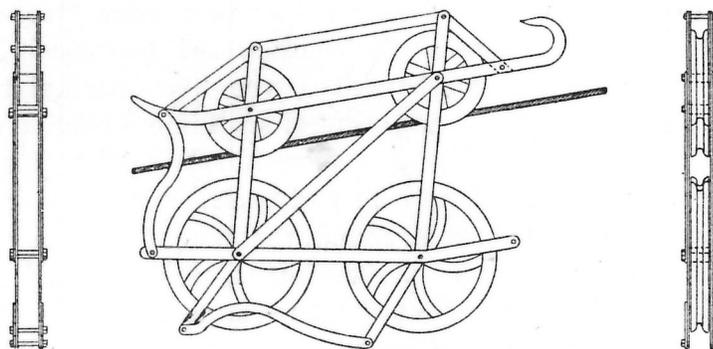

FIG. 25.—Carrier for Cable Hoisting.

To obtain control of the carriage so that the load may be picked up or lowered at any point without shifting the stop (e) on the carrier rope, a third rope is required, which is attached to the carriage and is wound in at the same speed as the fall rope after the load has been lifted.

DISPOSAL OF ROCK AND RUN OF MINE.

The hoists employed are of the double cylinder type of the usual construction; in one or two exceptions only single cylinder hoists are in use. The refuse rock is hoisted in steel buckets which slide on skids in the inclined and swing free in the vertical shafts; they hold from 400 lbs. to 800 lbs. of rock. The buckets are emptied into dumping cars. In quarry work boxes are used, which are filled with debris and placed on trucks and then wheeled out to the dump. All mines use steel rails of the lighter sort, nineteen pounds to the yard, mostly of Canadian make. The

crude mica is generally carted to the cobbing shed but where sheds of a temporary character are placed right on the edge of the pits it is carried by hand. Where the cobbing is performed in a special and permanent establishment, the mica is railed.

COST OF MINING.

Owing to the variation in the character of the deposits met with in mines even of the same locality, it is impossible to generalize on the subject of the cost of mining. In one mine expenses may be double those of its neighbour. In order, however, to give some approximate idea of what the cost of production may be, the writer has chosen the example of a mine which has been regularly working for years under conditions generally considered not too favourable, so far as the character of the deposit is concerned. This deposit constituted a vein-like accumulation of mica crystals, which, at times, were of such inferior quality as to render a very large percentage useless for the trade. However, the vein also produced very fine crystals, sometimes in large quantity, so that, taking it all round, the mine may be considered as working with fair success. The depth was from 150 to 190 feet and the deposit was opened up by large drifts, stoping and drifting being generally performed simultaneously. Drilling and hoisting were done by machinery. Two shifts were running; drilling was going on in both shifts, while hoisting was done only during the day shift. The average expenditure at this mine per day for twelve consecutive months was as follows:—

2 Steam drillers	\$3.50
2 Helpers	3.00
4 Muckers	5.20
2 Machinists	3.50
2 Drill boys	1.20
2 Bucket men	2.50
1 Blacksmith and Helper	3.00
1 Man and Horse	1.75
1 Foreman	2.50
Dynamite and blasting material	4.00
Fuel	5.50
Other material and supplies	2.00

Total expenses per diem \$37.65

An average of sixty tons of rock was hoisted daily, while the output of thumb trimmed mica was 600 pounds, cutting from 1x3 inches up. The daily wages paid for cobbing averaged \$10.00, so that the total daily expenditure at the mine was \$47.65, or \$158.83 per ton to which must be added general business expenses such as management, insurance, office, etc., amounting in the present case to approximately 150 dollars per month, or, calculated on a monthly production of seven and a half tons, twenty dollars per ton.

One ton of thumb trimmed mica of sizes from one to seven inches upwards was, therefore, produced at an average cost of less than \$179. This sum, however, does not include prospecting and exploring work, which in nearly all cases is carried on simultaneously with the deep mining.

PERCENTAGE OF MICA IN ROCK.

Apart from efficient management, the question whether a mica mine pays or does not pay depends on the percentage of commercially useful mica sheets in the rock. What, then, is the lowest percentage on which a mine can be made to pay?

To answer this question we must discriminate between quarry work, which is generally carried on in large pockety deposits, and underground workings where vein-like deposits, or deposits of a cobweb or cavity nature are mined. The quantity of rock to be hoisted in both cases is generally very large. Experience in different mines of the quarry class has shown that with present prices and in ordinary circumstances at least 750 lbs. of thumbtrimmed mica must be extracted for every 100 tons of rock in order to make the venture a paying concern. In underground mining the quantity of rock hoisted for a given quantity of mica is not so large since mining is more or less confined to the narrow shafts and drifts following the course of the veins or lenticular deposits. Experience shows that under ordinary circumstances at least 1,250 lbs. of trimmed mica must be extracted for every 100 tons of rock mined (the depth of the shafts not exceeding 300 feet) in order to pay a profit. The proportion of the run of mine is, of course, very much larger, in some cases being twenty times as much; in good paying mines, however, the run of mine should not be more than from eight to ten times the quantity of trimmed mica. In other words, in the case of quarry work, about three tons of run of mine yielding 750 lbs. and, in the

case of underground workings, about five tons of run of mine yielding 1,250 lbs. of thumbtrimmed mica should be extracted for every 100 tons of rock in order to make a mine, working under ordinary conditions, pay all expenses and leave a profit. Generally speaking, the above figures represent the experience of the mica mines of the Quebec division.

PERCENTAGE OF GRADES IN THE RUN OF MINE.

So much depends upon the character and quality of the deposits mined that it is difficult to compile averages of the different sizes, in the run of mine. Some deposits yield only small sizes of mica with a very small percentage of larger sizes, while others, but they are not frequent, yield a comparatively large percentage of the larger sizes.

One mine in the Wakefield township yielded with a certain regularity:—

61%	of thumbtrimmed mica cutting	1" x 3"
26%	"	" 2" x 3"
9%	"	" 2" x 4"
3%	"	" 3" x 5"
1%	"	" 4" x 6" and over.

A mine that delivers large sizes is the Battle Lake mine in the Templeton township. This mine has yielded since the beginning of operations, which have consisted mostly of open quarry work:—

36%	of thumbtrimmed mica cutting	2" x 3"
27%	"	" 2" x 4"
20%	"	" 3" x 5"
17%	"	" 4" x 6", 5" x 8" and over.

Another mine which delivers exceptionally large sizes is the Lacey mine near Sydenham. Crystals measuring five feet in diameter, yielding an extraordinary quantity of commercially useful mica sheets of large size, have been found here, while others of two and three feet diameter are a daily occurrence.

Generally speaking, a deposit of fairly good quality should yield, as an average, about:—

50%	of thumbtrimmed mica cutting	1" x 3"
30%	"	" 2" x 3"
10%	"	" 2" x 4"
6%	"	" 3" x 5"
4%	"	" 4" x 6" and over.

Preparation of the Mica.

Some ten or twelve years ago only the sizes of two inches by four and upwards were in demand, anything smaller than this was hardly saleable. Today most of the demand is for the smaller sizes. This change is due to an invention which has for its purpose the replacement of the large size* sheets by what is known as micanite.

This micanite or "mica board," if we may so call it, is made by building up layer after layer of the thinnest mica films. A coating of a special cement or adhesive containing shellac is placed between the layers and the whole is subjected to hydraulic pressure. This new application of mica implies the production of the very finest mica films. It has brought the smaller sizes into demand and has been the cause of placing many a mine in a sounder position both as regards its markets and its life. The process of sorting and handling of the mica from the moment it leaves the pit mouth until it is ready for the market is as follows:—

The run of mine is thoroughly cleaned of the adhering rock matter; the crystals or fragments which are not wrinkled or which show no crevices are split up into plates of about a sixteenth of an inch thick, a short handled knife sharpened, towards the point, on both edges, being employed. The rough edges are thumb trimmed and graded. An important item of the trimming and dressing operations consists of splitting the mica for the purpose of removing damaged films and fine layers, or inclusions, of foreign minerals, which would, if allowed to remain, reduce the market value of the whole sheet. This part of the dressing requires good judgment though its importance is not always fully appreciated.

One person can clean and thumbtrim from 35 to 45 pounds of medium sized sheets in ten hours. Each size is, by means of a hand-press, pressed firmly into a barrel (generally a sugar barrel) holding about 325 pounds. The packed mica is then shipped to the trimming works, of which there are several in each district; the largest are owned by the General Electric Company, Ltd., and the Laurentide Mica Company at Ottawa. The mica is again subjected to a thorough cleaning; the sheets are more carefully resorted, all those with small cracks or uneven lamination being rejected. The selected plates are split again, then knife trimmed. Most of the factories employ machine knives

*Large size is generally understood to refer to plates of four inches by six and upwards.

for this purpose. These knives (Fig. 26) consist mainly of a lever-shaped bar (A), solid iron frame (B), excentre (C) and spring (D). The iron bar (A) holds the blade (E) and makes a swinging motion round pivot (G) caused by the excentre and spring. The blade is two inches wide and ten inches long and can be detached when required. In order to prevent accidents a round iron bar (F) is placed just over the feeding plane (H) and in front of the blade, thus only allowing a small space, not larger than a quarter of an inch, for the passage of the mica plates. The knife makes from 180 to 200 motions per minute. The motive power is electricity.

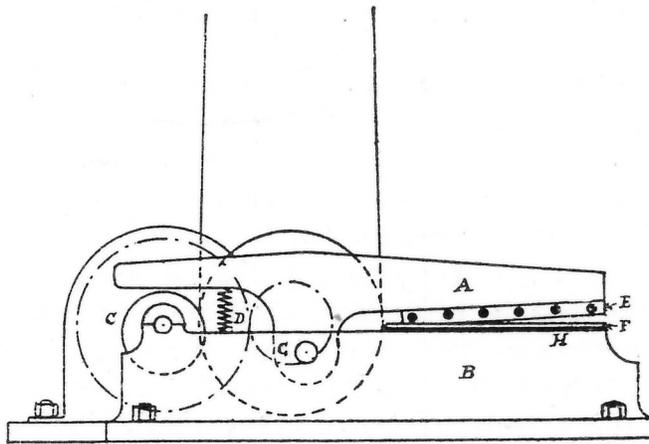

FIG. 26.—Machine Mica Cutting Knife.

After the rough edges have been cut by these machines, the trimmed sheets are again graded into the different sizes and then delivered to the thin splitting department. Here the sheets are ground on one edge with fine sand in order to facilitate the splitting and are then divided by specially made knives into films one five-hundredth of an inch in thickness and even finer than this. The operation of thin splitting has to be performed with so much care that one girl, in a day of ten hours, is only able to split from seven to twelve pounds of sheets measuring two by four inches and less. The larger sizes are not generally thin split; after being, in general, knife trimmed, they are shipped in boxes of 125 pounds. The thin splits or films are made up in little packages graded according to size and shipped in similar boxes to the electric concerns abroad, mostly for the manufacture of mica board.

Sheets of less than one by three inches cannot at present be used for the purposes to which mica has hitherto been put, but there is a movement on foot now for the application of this grade.

There are very large stores of this material on hand and if some practical use for this size can be found there is no doubt that many mines which cannot live under present conditions would have a chance to resume operations.

GROUND MICA.

In recent years the preparation of ground mica has become an industry in itself and several Canadian firms have gone into the business. Waste or scrap mica, the refuse of the cobbing sheds, is generally used. The difficulties of grinding are great owing to the tough and scaly nature of the mineral. Mills which work well on almost everything else fail utterly on mica. Recently there has been a return to the old fashioned burstones. Most of the manufacturers keep their process a secret. Some of them grind mica to a very fine powder for specialties; the standard sizes are 20, 40, 60, 70, 80, 100, 140, 160 and 200 meshes to the inch and the prices range from five cents to ten cents a pound.

Scrap mica for grinding is bought for eight to ten dollars a ton. It must be free from rust or gangue which would affect both the colour and lustre of the product.

The process of grinding, as employed by the International Mica Company of Gananoque, Ontario, is as follows:—The mica is first roughly screened and then cleaned before entering the grinder, which is a sheet iron cylinder nine feet long by thirty inches in diameter, punched in rows and set at an incline of one inch and a half in its length. As the machine slowly revolves, loose pieces of steel, enclosed in the cylinder, pulverize the mica until fine enough to drop through the holes which are three-sixteenths of an inch in diameter. It is then sized and graded in trommels from flakes down to the finest powder, the finest screens being of silk. The plant is operated by water power on the Gananoque river.

The application of ground mica in the arts and for technical purposes is manifold, the principal markets being in England and Germany. The duty of 25% imposed by the United States prevents shipment to that country.

CHAPTER IV.

MICA MINES AND LOCATIONS.

In the following descriptions all the prominent mica mines and locations in Canada are enumerated and details are given as far as information is available of the most important ones, including those actually producing and those that have suspended operations pending a betterment of the mica market.

Province of Quebec.

TOWNSHIP OF TEMPLETON.

In the Ottawa county an old and large producer is the *Wallingford* mine (Fig. 27 and Figs. 14 and 15) belonging to the Wallingford Mica Co., Ltd. It comprises the west half of lot 16 and

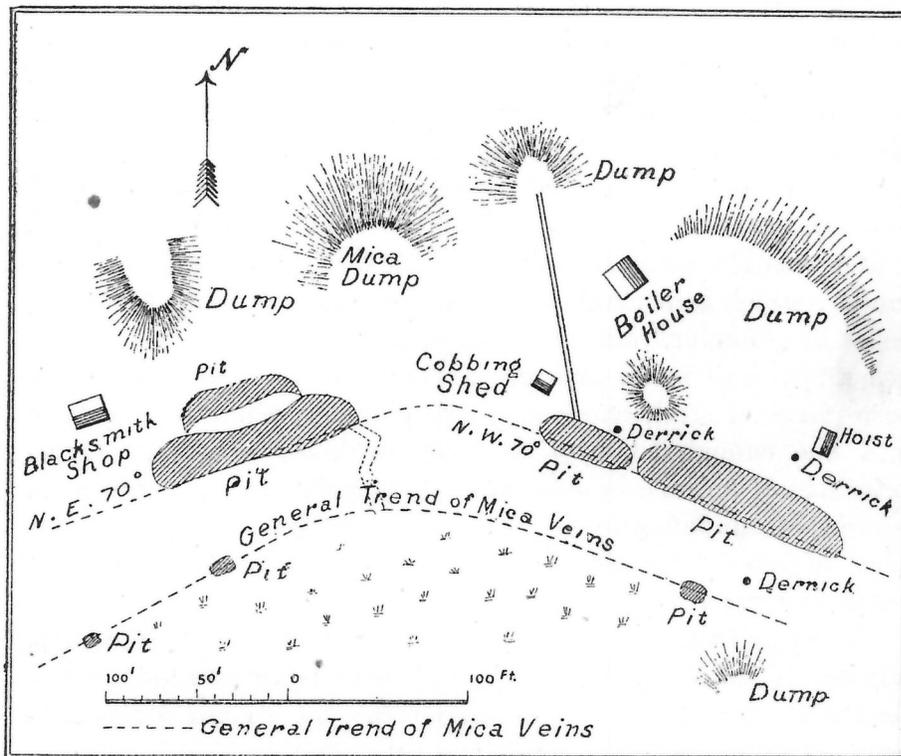

FIG. 27.—Surface Plan of Wallingford Mine.

the south half of lot 17 in the eighth range of the township of Templeton, covering in all about 200 acres. This mine was worked some twenty years ago for apatite and is said to have

produced large quantities. The main deposits where mining is going on are contact deposits between the older formation, a grayish and red gneiss, and the younger rock pyroxene. These deposits are of considerable extent, one of them having been partially explored for a length of over 370 feet; the main openings have a length of 120 and 170 feet respectively, with depths of 125 and 200 feet. The mica forms vein-like accumulations near the solid wall of the older formation in thicknesses from twelve inches to twelve feet. Apatite and calcite are frequent companions in this mine, the former at times occurring in such large compact masses and of such high grade (yielding over 85% phosphate of lime) that its mining, in spite of the prevailing low prices (\$9.00 a ton) is well repaid. The underground work on this property consists of drifts along the mica vein and cross-cuts from the bottom of the 125 ft. shaft to other parallel deposits, the outcrops of which appear on the southern side of this shaft. Generally, the veins on this property continue in great regularity and although, at times, dead ground interrupts the regular course of the mica accumulations experience has shown that these interruptions are of no account and do not influence the regular and steady supply of mica.

The Wallingford property has been a steady producer since its discovery in 1893 and up to October, 1896, when the writer made his first examination of this property, 472 tons of thumb-trimmed mica had been shipped from the mine. The output per month averaged twelve tons and the average number of men employed was nineteen. Mica cutting less than two by three inches was not then saleable and was thrown into the dump, otherwise the recorded output during the above period would have been considerably higher. These very large dumps containing mica eventually became, of course, a valuable and realizable asset when the demand for small sheets sprang up.

The mine is well equipped with an adequate plant, consisting of a 50 horse-power boiler, three pumps, two double cylinder hoists, four derricks, five three inch Ingersoll drills and all accessories for the employment of a large force. The camp is built for the accommodation of sixty men.

The *Battle Lake* property (Fig. 28 and Fig. 17), belonging also to the Wallingford Mica Co., is remarkable on account of its production of large sized mica. It comprises lots 4 and 5, range XIII, township of Templeton, county of Ottawa, covering in all

an area of 400 acres, but almost half of this area is taken up by two nearly parallel lakes, Battle lake in the south and Rheaume lake in the north. The distance from the nearest railway station is twelve miles. This property, also, was worked some twenty years ago for apatite; large quantities of this mineral are said to have been shipped by way of the Lievre river, two and half miles distant. Evidence to this effect is given by the number of old and large excavations on the property. The mica deposits of productive value occur on the north shore of Battle lake in a dike of pyroxene, cutting the gneiss strata in a north east south westerly direction. They occupy fissures in this rock which are almost parallel to each other at intervals of five, ten or more feet. These fissures are connected with each other by smaller veins of mica or cavities filled with mica crystals, thus giving the whole a cobwebby appearance. The deposits commence with the contact line between the gneiss and pyroxene, near the lake shore, and

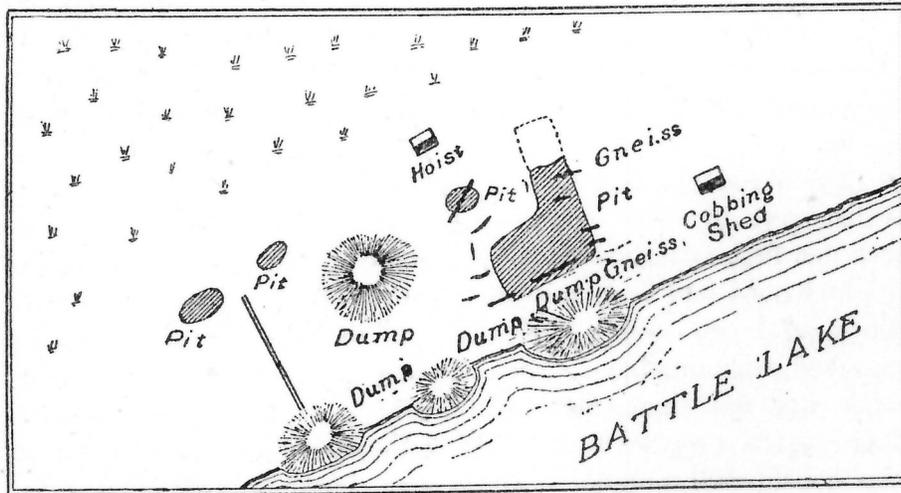

FIG. 28.—Surface Plan of Battle Lake Mine.

end with a chain of mica deposits at the crest of the hill further north. The main works consist of a longitudinal opening, fifty feet long, thirty feet wide and twenty feet deep, running along the solid wall of gneiss. A little further north on the hill a pit has been sunk on a mica vein parallel to those worked in the quarry. This pit is twenty-five feet deep and ten feet by twelve feet square and follows a mica vein, the section of which is illustrated in Fig. 17. The mica crystals are imbedded in a soft pyroxene matrix, while the different branches of the mica vein are separated from each other by hard pyroxene and granitic boulders.

Bush fires have exposed most of the country rock of a steep hill rising to 200 feet above the north shore of Rheaume lake and four outcrops of mica crystals in a dike of pyroxene may be seen. At one place a pegmatite vein runs along this dike and amber mica crystals of perfect form and cleavage are exhibited at the contact. At another place in close proximity three large crystals can be noticed, one of them measuring three feet in length and apparently of large diameter.

A careful estimate places the quantity of rock shifted from the principal excavation on Battle lake and from two small neighbouring pits at 2,800 tons; the thumtrimmed mica extracted was approximately twenty-five tons or 0.9% of the total rock hoisted. This percentage is far above the average and must be pronounced for open quarry work a very favourable result. Since the commencement of operations, seventeen per cent. of the total output of sheets cut four inches by six and over. One crystal, weighing 200 lbs., cut fourteen inches by nineteen, while another gave commercially useful sheets measuring nineteen and a half by twenty-seven inches. The mine is furnished with the requisite machinery, consisting of a 30 h.p. boiler, one Ledgerwood hoist, two three inch Ingersoll drills, three derricks and all accessories. A spacious boarding house provides accommodation for thirty miners.

The *Rheaume Lake Mine* on lot eight, in the Gore of Templeton is another striking example of a contact deposit between pyroxene and gneiss. The whole pyroxene dike, which strikes northeasterly through a red and grayish gneiss, is full of cavities, which are all lined near the contact with fine mica crystals, mostly imbedded in a calcite matrix. In one pit, twenty-five feet deep, a cavity has been followed along the solid wall of the country rock, branching off in spurs filled with mica crystals and separated by a garnetiferous pyroxene granite (Fig. 18). Small boulders of a very hard pyroxene are frequently met with, interrupting the course of these branches, and drilling in these boulders is very difficult. Apatite of a high grade is also found in most of the open pits and, judging from the many indications, it seems probable that both mica and apatite can here be worked together advantageously. All drilling on this newly opened property is at present done by hand.

The *Blackburn Mine*, another large mica mine, has been worked for more than twenty years for apatite and has produced,

it is recorded, over one hundred thousand tons of this mineral. Up to 1888 it was operated under the names of R. Blackburn and T. Maclaren; from 1888 to 1895 by the East Templeton District Phosphate Mining Syndicate, Ltd., and since then by Messrs. Blackburn Bros. of Ottawa. It comprises a block of mineral lands of 900 acres in the vicinity of McGregor lake, but since the beginning of operations, which date back as far as 1870, the principal work has been confined to lot ten, range eleven, of the township of Templeton. During the mining of apatite large quantities of mica were encountered and much difficulty was sometimes experienced in producing a clean, high-grade article. The mica was thrown away as useless, but when the demand set in, most of the large dumps were sorted, machinery was installed and, for a time, quite an industry was established. From twenty to thirty persons were employed on these dumps alone during 1893 and the quantity of mica extracted was very large. Since 1895 the mine has been worked for mica under the personal management of Messrs. Blackburn Bros., with Mr. S. Baker as superintendent. A first-class plant has been installed, consisting of two forty h.p. boilers, two large cable derricks with steam hoists, one air compressor, three air drills and one 60-light dynamo. A force of sixty men is steadily employed. Air is also used for pumping. The camp consists of a sleeping house for 100 men, a large cook house, a stable for fifteen teams of horses, store house, superintendent's quarters and foreman's dwelling.

The workings comprise an open quarry 200 feet long and 100 feet wide with a depth of 60 feet, also one vertical shaft, which is now being sunk from the 240 to the 280 foot level. The main vein, which has been opened up for over 250 feet by a drift at the 180 foot level, has been explored to the 240 foot level and it consists for the greater part of large chain-like accumulations of mica crystals, imbedded in a matrix of soft, pale green pyroxene, occasionally intermixed with calcite and phosphate. The mica is roughly cobbled at the mine and shipped to the Company's works at Ottawa, where it is prepared for the market. Forty persons are regularly employed at these works.

Adjoining the Blackburn property is that belonging to the *Canada Industrial Company of Montreal*, lot 9, range X. This property also was a producer of apatite previous to 1891 and during these operations the occurrence of large deposits of mica was established. The main workings consist of an open

cut into the hillside for a length of 120 feet (Fig. 29) and a pit forty-five feet deep sunk at the end of this cut along a vein of mica which occurs at the contact between pyroxene and the gneiss formation. This pit has produced crystals of large size in connection with apatite mining.

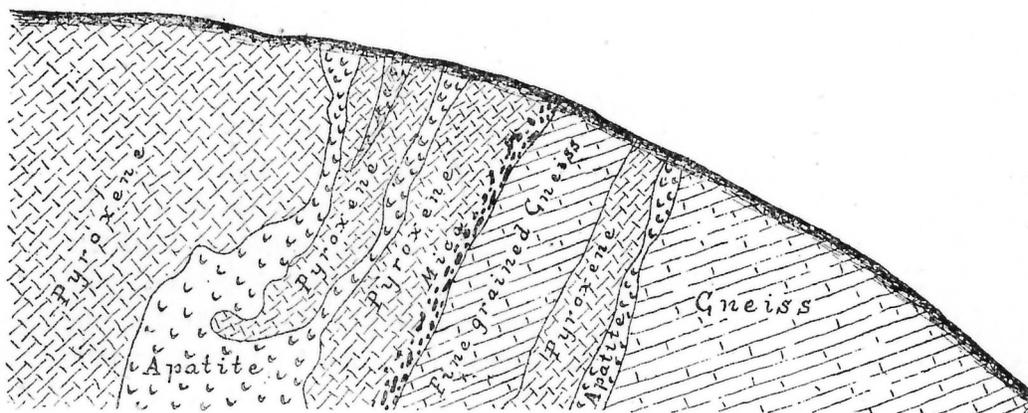

FIG. 29.—Cut Through Workings on Lot 9, Range X, Templeton, Owned by the Canada Industrial Co.

In addition to the properties above described there are in the township of Templeton a large number of locations, which, by reason of the appearance of the outcrops, give encouragement for further exploitation. Amongst these may be mentioned:—

*Range IV, lot 21.—Mica outcrops located on Mr. McTiernan's property.

Lot 22.—Belonging to Mr. Taylor McVeity. This is an phosphate property but was reopened for mica in 1898. Several hundredweights of cut mica have been produced.

*Range V, lot 20.—Outcrops reported by the proprietor, Wm. Smith.

Range VI, lot 17A and 21B.—These properties belong to the Canada Industrial Co. of Montreal and have been worked for apatite. All the dumps contain a large amount of mica, while new outcrops have been located on the property.

*Range VII, lot 10.—This is the A. Stevenson mica property, worked intermittently by Charrette, by Jos. Fortin and in 1900 by J. E. Asquith, of Ottawa. About twenty men were employed and a fair quantity of good mica crystals

*All notes marked * have been taken from Mr. Obalski's Report on Mica, 1901.

have been raised. The distance from East Templeton is ten miles.

*Lot 14.—This property has been prospected by the American Mica Co., of Boston, and good outcrops have been located.

East Half of lot 15.—The southern part of this property contains mica in connection with apatite. It belonged originally to Judge Dugas of Dawson city and Father Forget of Embrun, who worked the same from 1891 to 1893 for asbestos and after 1893 for mica. The old apatite dumps delivered seventeen tons of very good mica, some crystals measuring 40 x 48 inches. In 1896 and 1897 the mine was taken over by Mr. Manchester of Ottawa, who erected an adequate plant and worked the mine for one year. In 1897 Mr. W. Webster with a force of twenty men produced a large quantity of mica, while promising outcrops were located by extensive prospecting work.

The indications are very favourable and there seems to be no doubt that this property, if properly handled, may turn out a large producer. One important feature is that the crystals in comparison with those of other mines are nearly all well defined and perfect in shape, the prismatic edges being well preserved, while few wrinkles or crevices can be detected.

West Half of lot 15.—This mine, situated on a hill 300 feet high, is known under the name of *Phosphate King* (Fig. 21) on account of the large quantities of apatite it has produced. It was successfully operated in 1895 by the Lake Girard Mica System, which installed a fine plant and constructed good roads to the mine. In 1896 and 1897 Webster & Co. of Boston worked this property with a force of thirty men and are reported to have taken out a large quantity of mica. In 1897 the Mica Mining and Manufacturing Co. of London, England, took over all the properties of the Lake Girard Mica System and worked here with a force of fifty men until 1899. The main workings consist of an inclined shaft of seventy feet, which follows a large deposit of green apatite, holding mica crystals disseminated through the mass. Several hundred tons of mica and apatite have been extracted, but, from the appearance of the workings

it is evident that the principal object was simply to take the mineral where it was convenient to mine, without any regard to the future of the property.

*Range IX, lot 4.—In 1892 this property was operated by Lee Bros. Work was carried on intermittently in a shaft 100 feet deep, which followed a deposit of mica. In 1900 the mine was worked again with fair success.

*Lot 14.—This is an old phosphate property and has been prospected and worked intermittently, with success, since 1894. The old workings consist of several large excavations on veins, from two to twelve feet thick, containing a large amount of calcite in which mica crystals, many of them of considerable size, are imbedded. Apatite is also found in connection with the mica, of which it is reported recently that some very fine outcrops have been discovered.

Lot 16.—This, the property of the Canada Industrial Company, shows some very substantial outcrops of mica.

*Range X, lot 8.—Known as the *Marcelais Mine*, is situated ten miles from East Templeton. It belongs to the Templeton and North Ottawa Mining Co. whose head offices are at Montreal. The property was worked extensively for apatite many years ago and all the dumps resulting from the early operations held a large amount of mica, which was sorted in 1897. Subsequently operations were resumed by Messrs. Powell and Haycock of Ottawa, but the results have not been made known.

West Half of lot 9.—This is the well known *Jackson Rae* property, famous in the eighties for the production of very large quantities of apatite. At the same time mica was extracted and in 1891 and 1892 all the dumps were reworked and a considerable quantity of mica recovered. Lately, several promising outcrops have been located but not exploited. All the mines in this group are twelve to fifteen miles from East Templeton station.

East Half of lot 9.—This property, owned by the Canada Industrial Company of Montreal and known as the *Post Mine*, was a producer of apatite on a large scale during the eighties. A number of pits and crosscuts have been made, which show more or less the occurrence of phosphate in connection with mica. A section through the formation, as it presents

itself in one of the crosscuts, is shown in Fig. 29. In one of the shafts a mica crystal was raised weighing over one ton, but on account of the limited demand for mica at that time, the crystal could not be utilized. All the old phosphate dumps on the property exhibit a large amount of mica fragments, demonstrating that the mica is intimately associated with apatite. Some of these dumps have been worked over from time to time and it is reported that a large quantity of merchantable mica was recovered.

North Half of lot 10.—Known as the *Jubilee Mine*. This is an old productive phosphate property and was explored and worked for mica in 1894, again in 1897 and again in 1900 by Messrs. McLaurin and McLaren of East Templeton, who installed machinery. A considerable amount of work was done and a fine quality of mica extracted.

South Half of lot 10.—*Murphy Mine*. The Lake Girard Mica System worked this mine for apatite and mica in 1892. In 1900, Mr. Murphy, the owner, leased the property to the Sills-Eddy Co., which worked there for some time, but did not publish results.

*West Half of lot 15.—Worked in 1893. It is reported that several tons of mica were extracted.

North Half of lot 16.—This property, belonging to the Canada Industrial Company of Montreal, was worked for apatite in the eighties. Several fine outcrops of both apatite and mica have been located on the property but no further work has been done.

South Half of lot 16.—*Victoria Mine*, belonging to Messrs. McLaurin and McLaren. In 1899 machinery was erected and fifteen men were employed to work the mine. The main work consists of an open cut 200 feet long and 60 feet deep. Much apatite in connection with mica has been found and the outcrops so far located look very encouraging.

Lot 28.—Belonging to the Canada Industrial Company. This property was worked in the eighties on a large scale for apatite and mica was raised in considerable quantities during these operations. It has, however, never been worked specially for mica, but it is reported that work will be resumed shortly.

The following properties in the township of Templeton have been prospected and good outcrops have been located:—

- *Range XI, lots 12, 14 and the north half of lot 20.
- *Range XII, north half of lots 12, 13, 14, 24 and 27.
- *Range XIII, lots 3, 4, 5, 13 and 17.

In the Gore of Templeton there are very good properties which have been worked for apatite and to some extent for mica, but the remoteness of the district is a drawback to their successful exploitation. When the supply of mica from the Templeton properties commences to slacken, this district may come into prominence.

TOWNSHIP OF PORTLAND WEST.

In the township of Portland West several good properties have been worked, but here also the lack of easy communication is a hindrance to successful mining.

- *Range III, lots 12 and 13.—This property has been known under the name *Lake Terror Mine*. It was prospected by Lewis Bros. & Co. and some fine outcrops were located. Operations, which may be resumed here at any time, have a fair chance of success. Some apatite locations have also been made.
- *Lot 14.—Indications of mica were found.
- Lot 15.—J. A. Chabot & Co., of Ottawa, worked this mine in 1899. It is situated on the crest of a hill 500 feet high. Several tons of good mica have been extracted. The mine is accessible either from Wakefield by the Wakefield road or from the Lievre river road.
- *Lot 16.—Indications of mica were found.
- *North Half of lot 24.—Operated by the Lila Mining Co. of Ottawa in 1899 with a force of twenty men. Mica was found in connection with calcite in a large dike of pyroxene. The crystals were of perfect shape and many of them measured five inches by ten. The mine is thirty miles from Ottawa and is situated on a hill 300 feet high. Work was continued in 1900 and 1901 with great success. The condition of the roads leading to the mine has been materially improved.

*South Half of lot 24.—Worked by Mr. J. Doller of San Francisco with a force of eight men. The indications are favourable.

*Range IV, lots 16, 17, 18.—Outcrops of mica located.

*Lots 26, 27, 28.—These are old phosphate properties belonging to Messrs. Fleming and Allan, of Ottawa. They were leased in 1891-92-93 to H. McRae, of Ottawa, who worked them with a force of forty men for apatite and mica. The quantity of mica raised is reported to have been considerable. A number of pits and excavations are distributed over the surface of a high ridge of gneiss, which is cut by light green pyroxene dikes containing some iron pyrites. Pink calcite is found, frequently holding red and green apatite crystals, while quantities of massive apatite are found with the pyroxene. At several points the latter is cut by dike-like masses of almost pure feldspar of a white and sometimes pink colour. To the south of this, on the ridge near the lake, several openings for mica have been made. On the north side of the ridge a large mass of white granite, mixed with pyroxene, occurs, in which is an irregular vein of calcite with mica crystals. This mass can be traced down the slope of the hill for more than one hundred yards. The other, or more southerly mine, is near the summit of the ridge near the line between ranges III and IV. The calcite forms a vein in a course north and south and pyroxene and granite intrusions are frequent. The mica is dark amber and appears to occur in the pyroxene near the contact with the granite.

Range V, lots 24, 25.—Prospected by the Lake Girard Mica System.

*Range IX, lots 5, 6.—These old phosphate properties, belonging to the Canadian Phosphate Co., were worked previous to 1892 by Mr. W. McIntosh, who extracted several tons of good mica. In 1892 operations on a small scale were resumed by Angus Cameron of Buckingham, who raised mica crystals of large dimensions. Work was continued until 1900 with good success, when the mines were shut down.

*Range X, lots 1, 2.—Indications of mica were found.

TOWNSHIP OF PORTLAND EAST.

*Range I, East Half of lot 1.—Developed by Mr. Poupore in 1893.

A small staff extracted several tons of mica. Work was resumed in 1900 and gave good results.

Lot 1, East Half, and lot 2.—This property belongs to the Glen Almond Mica and Mining Co. and has been thoroughly prospected. Some thirty substantial outcrops of mica have been located on the slope of a hilly ridge sixty to one hundred feet high. The workings consist chiefly of long trenches and crosscuts through the formation, with small pits, drifts, shafts and excavations of an irregular character. On one place the pyroxene rock is honey-combed with crevices and cavities, which are lined with well defined mica crystals two inches by four and upwards. Six shallow pits have been sunk on these occurrences, near the contact with the gneiss formation; substantial pockets, bunches and accumulations of mica crystals have been laid open. In many places on the property crystals of the large sizes outcrop in the rock, while the soil is permeated with loose mica sheets, evidently showing the existence of mica beneath or not far off. This promising property has been worked with a force of twenty men in 1900, 1901 and 1902 and it is reported that operations will shortly be resumed.

*Lot 6.—Known as the *Little Rapids Mine*, an old phosphate producer. Was worked by the owner, Mr. W. A. Allan, of Ottawa, and several tons of good mica were extracted.

TOWNSHIP OF DERRY.

*Range I, lot 7.—Worked in 1899 by D. Cameron. Results not made known.

*Lot 9.—This property, fourteen miles from Buckingham, belonging to Mr. W. A. Allan of Ottawa, was worked in 1900 with a force of seven men; several tons of good mica were extracted. The workings consist of small pits, trenches and excavations in pyroxene rock.

*Lot 23.—Prospected in 1897 by Mr. McTiernan with several men. Three tons of mica have been mined.

Range II, lot 23.—Property of the Glen Almond Mica and Mining Co. Has been partially prospected. A pit was sunk fol-

lowing a vein-like deposit yielding several tons of mica of good quality.

*Range III, lots 3, 4, 6.—Has been prospected by the same Company with satisfactory results.

TOWNSHIP OF HULL.

West side of the Gatineau River.

*Range VI, lot 19.—North half. Worked in 1899 and 1900. Has been prospected and some mica was mined.

Lot 20.—Prospected in 1900 but results not reported.

*Range VII, lot 18.—Owners, Messrs. Fortin and Gravel. This property was opened in 1899 and worked with a force of eight men. The main workings consist of two openings thirty feet along a vein of mica from four to five feet wide in pyroxene rock. A large quantity of large sized mica crystals was mined. Work was continued throughout the year 1900 with very satisfactory results.

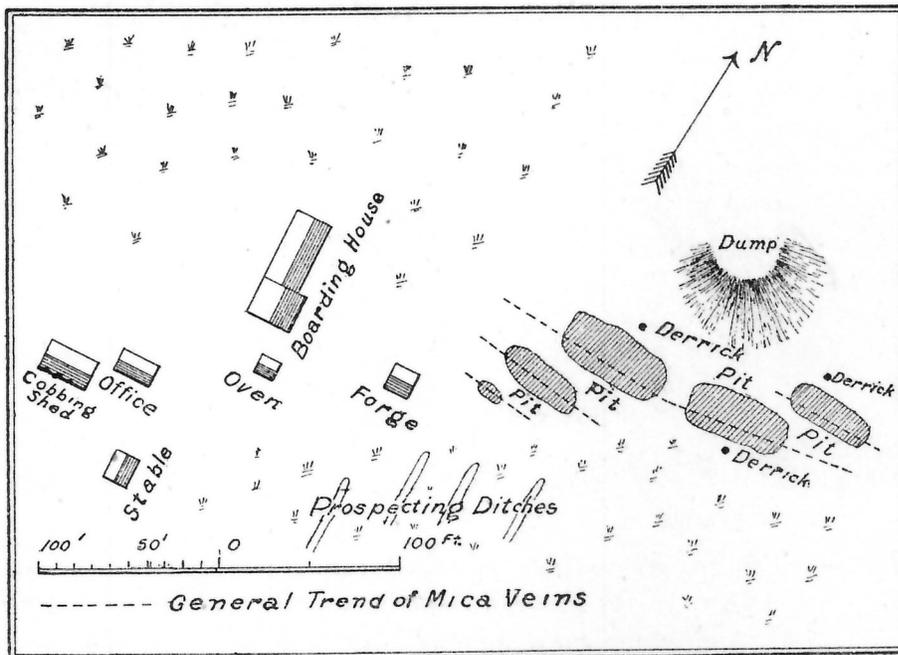

FIG. 30.—Surface plan of the Laurentide Mica Company's mine.

Lot 19.—This property originally belonged to Brown Bros., but has lately been transferred to the Laurentide Mica Co. of Ottawa (Fig. 30). This American Company is at present vigorously developing their property with a force of fifty men. Although there is no machinery on the ground, a

considerable amount of work has been done all over the property since the Company came into possession in February last. A large mining camp has sprung up, a spacious boarding house for the accommodation of seventy-five men, store house, cobbing shed, office, stables, etc., have been erected and are all well protected against fire; good roads leading to and over the property have been constructed. The main workings consist of three nearly parallel openings in a pyroxene dike which runs in an east and westerly direction, dipping north, through a gray granitic gneiss formation. The principal pit was fifty-eight feet long, twenty-four feet wide and twenty-two feet deep. The mica occurs in calcite in a vein-like accumulation from four to five feet wide, containing crystals of high grade; many of them of large size. The pink calcite frequently holds apatite crystals of a light green colour, but no large masses of this mineral have been encountered. Three horse derricks are in use and machinery is being installed. There are a great many other pits, excavations, cuts, trenches and prospecting ditches all over the property; part of them have been abandoned, but work may be resumed if the demand for mica warrants it. The whole property is systematically developed in every possible direction to determine its value and no money is spared to reach that end. This mine is a striking example of the thoroughness with which a new mica property should be tested. The work done here is in strong contrast to those operations so frequently conducted by persons who have no regard for the future of a property.

*South Half of lot 20.—*Fleury Mine*. This property has been worked intermittently on a small scale but the results of the operations are not published. One crystal weighing 500 lbs. and cutting sheets 24 by 28 inches has been found on this lot.

*Range IX, lots 14 and 15.—Known as the *Scott Mine*. At the south opening the country rock is a reddish and gray gneiss, cut by small irregular dikes of pyroxene, which carry small quantities of apatite and mica. The gneiss has a dip to the southeast and the limestone in the adjacent valley dips to the east. In the main pit, a quarter of a mile to the north-

east the gneiss is well banded and cut by dikes of pyroxene, granite and diorite. Some ten or twelve tons of mica crystals were taken from this place. Red apatite also occurs, and here and there we find small patches of a bright red jasper. Another opening in pyroxene associated with crystalline limestone carries little mica. The property was worked in 1892 by M. G. Robertson.

Lots 13, 14, 16, 23, have been prospected and some of them worked but particulars are not at hand.

Lots 15, 17.—Pyroxene masses in gneiss carrying mica were noted. In one of the openings the pyroxene shows green apatite in calcite with small mica crystals. Going west the intrusive mass also contained dark coloured mica, as is the case in the third pit, where the country rock is a gray and red gneiss. The mica is dark and in small crystals.

Range XI, lot 14.—This property was worked some years ago and produced some good mica. A gray and red gneiss occurs here, dipping east, and is cut by dikes of pyroxene from one to three feet wide. At one point two small dikes converge and in the cavity near the intersection many small crystals of apatite occur, mostly red in colour. Further north on the hill a larger dike has been opened, from which a number of large sized mica crystals, cutting ten to fifteen inches across the planes, were obtained. A considerable quantity of apatite was also mined at this place.

Range XV, lots 22 and 23.—This is the well known *Cascades Mine*, which has delivered for ten years with slight interruptions since 1891 a very large amount of mica. Crystals of large size have been frequently found on this property and although much of the mica is crushed and contorted a large percentage of commercially useful sheets have been raised. One large crystal, measuring seven feet in length by several feet across, yielded 6,300 lbs. of run of mine mica. There are a great many openings on the property, apparently along the fissures between the pyroxene and country rock and no regular trend of the mica bearing formation can be followed. The occurrence of mica appears to be very pockety; this is evidenced by the fact that all openings are distributed irregularly over the pyroxene belt and show, in most cases, a shallow depth. Calcite in connection with

mica is not generally observed, while apatite crystals may be frequently seen in the pits. This mine is an illustration of the pocket type. The property is situated about one mile from the Cascades station. There is little doubt that if operations were continued in depth the mine could be made a steady producer of good quality mica.

TOWNSHIP OF HULL.

East side of the Gatineau River.

*Range X, lot 7.—Known as *Foley Mine*. Messrs. Clemow and Powell of Ottawa have worked this property intermittently from 1892 to 1895 and are reported to have taken out some thirty tons of mica. The deposits occur, in most cases, near the contact between pyroxene and reddish gneiss. Apatite is met with in small bunches but cannot be extracted economically on account of impurities from micaeous matter.

*Range XI, lot 10.—This mine located ten miles from Ottawa, was worked to a large extent early in the nineties under the name *Nellie and Blanche* by the Lake Girard Mica System. The "Nellie and Blanche" is a deposit of the pocket type; the mica occurs irregularly distributed along fissure lines in a large belt of pyroxene, in which pockets of apatite also occur. Calcite is met with and although much of the mica raised is of a shattered and contorted nature, the percentage of good mica is above the average. It is reported that for the years 1890 and 1891 the monthly yield was nearly twenty-five tons of trimmed mica, which was sent to Ottawa to be prepared for the market. Operations were suspended in 1893 and have not since been resumed.

Range XII, lot 10.—Known as the *Nelles Mine* or *Vavasour Mine*. This property is remarkable on account of its mica outcrops. These outcrops appear to be parts of several veins striking through the property in an east and westerly direction. Over 2,400 feet of these veins can be traced in the prospecting ditches, pits and the great many openings which have been made. The last are situated on the slope of a small hill of a gray and reddish gneiss, which is cut by dikes of a pale green pyroxene. Most of the deposits are

of the true contact character and can be followed along the contact with the gneiss to a depth of forty, sixty and one hundred feet. The mica seems to be mostly imbedded in a matrix of calcite and the veins appear to be made up of a number of lenticular deposits from one to fifteen feet wide. The deepest shaft is 160 feet; it follows a line of contact between the gneiss and pyroxene. The main shafts and pits have yielded a considerable quantity of mica, the greater part of which was of the larger size. Operations were commenced in 1891 and have been continued intermittently since that time. It is reported that over 300 tons of trimmed mica have been taken from the property. On the most westerly portion of the hill a deposit of mica can be noticed near a contact with the gneiss dipping to the north 40° , it widens out in depth and appears to be regular in its outlines. The main pyroxene belt, in which nearly all the outcrops have been found, has been traced in a north-easterly direction for over 1,000 feet.

*Range XIII, lot 1.—This property, known as the *Burke Mine*, is an old phosphate mine, several hundred tons of this mineral having been extracted prior to the year 1890. During these operations mica was also mined but was, as usual thrown on the dump. The property has been worked from time to time since 1894 and the output of mica has been very satisfactory.

Lot 3.—A pyroxene dike cuts the country rock, composed of reddish gneiss, and on the contact along the lines of fissures the mica occurs in a matrix of calcite. There appears to be a large belt of pyroxene with mica deposits, but it is overlaid in some parts by a capping of gneiss.

Range XV, lot 12.—On this lot a large deposit of mica can be seen in a dike of pyroxene, which is capped by limestone. Pink calcite is the matrix of the mica crystals and is associated to some extent with fine crystals of apatite. The property has been but little opened up and offers a splendid chance for an energetic operator. On the adjoining lot, belonging to Mr. Chubbuck, (lot 13 in the 16th range) the pyroxene dike apparently continues and we find an opening about thirty feet deep where many mica crystals can be seen in a reddish calcite. The pyroxene is of a grayish green,

while the country rock, composed of gneiss and granitic masses, has a reddish colour. There are several other openings in which both mica and apatite were observed. This property has been operated at intervals from 1898 to 1900 and has given satisfactory results so far as the output of mica is concerned.

*Lots 13, 15, 16.—These lots show, more or less, the occurrence of mica similar to those above described and do not present any new features. Nearly all of them have been worked from time to time, but it appears that no earnest efforts were made to follow these deposits in depth.

*Range XVI, lot 12.—The mica found here occurs only in small crystals, but the deposits are interesting on account of the association of serpentine with the pyroxene. The latter cuts the crystalline limestone and at the contact a serpenized zone is observed, which can be followed for some distance.

*Lot 13.—A considerable development of calcite, in connection with some splendid deposits of apatite imbedded in pyroxene, can be noticed. The latter cuts the country rock, which is composed of a reddish gneiss.

*Lots 15, 16.—Known as *Cassidy's Mine*. This property is traversed by a wide belt of massive pyroxene, containing mica deposits along lines of fissures. These deposits form pocketly accumulations or veins of mica, which can be traced for some distance. No contact with the country rock can be observed in any of the openings and it appears that the principal mode of occurrence is in that of pockets of irregular shape. No calcite can be noticed, while apatite occurs only in small bunches. The crystals are generally of large size, but they split up and deliver a great deal of small sized ribbon mica. Operations on this property began in 1893 and were continued at intervals until 1901. It is reported that the mine gave a very satisfactory percentage of fine merchantable mica sheets.

In the immediate vicinity of this property is the *Macfarlane Mine*. This property, in marked contrast to the Cassidy's mine, shows a number of contact deposits between pyroxene and a grayish gneiss. In nearly all the small openings calcite and small pockets of apatite are met

with, while the mica is usually in large crystals, which, however, split up in smaller sheets. Iron pyrites is sometimes found in connection with the mica, but in these cases the latter is much crushed and twisted.

*Lot 17.—Known as *Horse Shoe Mine*. The Lake Girard Mica System worked this property extensively in 1891 and 1892. It has been thoroughly prospected; good mica was found and was treated in the cutting works at Ottawa. The principal deposit of mica occurs at the contact of the pyroxene belt with the gneiss where also irregular masses of calcite may be observed. A good proportion of the mica occurs in fine crystals, while the balance seems to have been subjected to a great many crushing movements of the formation. The property was abandoned several years ago.

TOWNSHIP OF WAKEFIELD.

*Range I, lots 6, 11, 13, 16, 18.—All these properties have been partly prospected and on a few lots some development work has been done. The deposits are of the usual pocket or contact type. No serious attempts have been made to follow them in depth.

*Lot 12.—Known as the *Mark Haldane Mine*. Several pits have been sunk on the side of a hill which appears to consist of a belt of pyroxene bordered by a red orthoclase gneiss. The mica occurs throughout on the contact of both of these rocks in crystals of appreciable size, yielding a fair percentage of fine merchantable sheets. The pyroxene dike is sometimes cut by dikes of pegmatite and, at the contact, bunches of iron pyrites occur. In one opening the pyroxene is hard and dark, the mica obtained therefrom having also a deep brown aspect. Apparently the character of the rock has an influence upon the containing mica. In another portion of the pyroxene, where it is a light green, the mica found therein is also of a much lighter colour.

Range II, lot 14.—On this property a pyroxene dike traverses the country rock in a northwesterly direction with a high dip to the northeast. Several pits have been sunk along the contact of the pyroxene and gneiss formation, from whose appearance it may be assumed that this part of the forma-

tion has been subjected to a great deal of crushing movements. The pyroxene is much shattered, while the mica is mostly broken up, delivering small sheets of mica. The latter generally occurs in the form of pockets and lenticular deposits along lines of fissures.

*Lot 15.—This is an old phosphate property, where all the dumps show a large amount of mica. These dumps have been reworked and actual mining operations for mica have been conducted for some time. A good quality of mica was found, also some apatite. The mine was in operation from 1897 to 1900.

*Lot 16.—Is known as the *Kodak Mica Mine* (Fig. 16). The main workings consist of a shaft sunk on the hanging wall of a well defined vein or lead having a strike of 4° east of north and a dip of 65° . The country rock is gneiss and the deposit in which this shaft has been sunk is a splendid example of a contact vein. The footwall is a light green pyroxene, slightly intermixed with apatite, the latter is not, however, in sufficient quantities to be of commercial value. The depth of the shaft from the adit is 100 feet. The main constituents of the vein are calcite and mica, occasionally intermixed with pyroxene and apatite. The calcite, which is pink coloured, is generally found near the hanging wall in a width of from one to three feet. The mica crystals are either imbedded in the same or form larger accumulations between the calcite and pyroxene. This shaft has yielded a large amount of a very fine quality of mica and operations are interrupted only on account of legal difficulties regarding the ownership. The property has a good working plant, a well developed water power on the creek of 40 h.p. generating electricity for hoisting and drilling purposes. There is a sawmill on Blackburn creek with a capacity of about 10,000 feet of lumber per day, also an auxiliary plant, consisting of a 20 h.p. upright boiler and a 15 h.p. engine.

*Lot 18.—Known as the *Seybold Mine*. This property has been worked for apatite and during these operations has shown a considerable amount of mica. The latter, as a rule, is dark, is associated with calcite and gives commercial sheets.

Lot 24.—The *Lake Girard Mine* (Fig. 20). This was at one time the most important mine in the district. It is one of the richest properties and has yielded, from 1890 to 1894, a very large quantity of mica of the best quality. It has been abandoned on the supposition that there was no more mica. The writer, who has had occasion to visit and examine the main workings on this property from time to time since 1892, entertains no doubt as to the existence of mica deposits at lower levels.

The country rock is a gray and reddish gneiss, which is traversed in the vicinity of Lake Girard by a dike-like mass of a light green pyroxene. The main shaft is sunk near the contact between the two rock masses to a depth of 165 feet at an incline of from 73° to 75° . From the 165 feet level, at a distance of twenty-five feet, another incline shaft has been sunk to a depth of forty-five feet, making a total depth of 210 feet. From the main shaft drifts have been run, following the course of the mica deposits, the longest of which was 140 feet to the east. The mica in this shaft occurs in large lenticular pockets of pink calcite, near the contact with the country rock, and delivers, on account of the absence of wrinkles and crevices, a very large percentage of fine commercial sheets. Most of the mica was of the larger sizes and anything below two inches by three was thrown into the dumps, but was subsequently gathered when the demand for the smaller sizes sprang up. All the mica was hauled to Ottawa, a distance of some twenty miles, where it was cut into sizes.

In 1893 when the writer made an examination of this property the average daily output for three months amounted to more than four and a half tons of roughly cleaned mica crystals. The average number of employees was forty-eight. For nine months the daily output was a little over three tons with about the same number of men. About seventy persons were steadily employed in the Ottawa cutting establishment. From September, 1891, to July, 1893, the total output amounted to 113,000 lbs. of mica cut to sizes, 109,545 lbs. of trimmed mica of all sizes and 1,250 tons of rough mica, cutting one inch by three. There are few mines in the district that can show a similar

record. The mine was equipped with an adequate plant, consisting of a seven air drill compressor, two horizontal boilers of 120 h.p., two hoists and two pumps. A large boarding-house and cook-house accommodated seventy-five men.

The mines and locations described above embrace nearly the whole northern territory, which has produced the greatest part of the Canadian mica. There are, however, a great many other outcrops outside this territory, but as on most of them there has not been sufficient development to enable an opinion to be given of their actual value, they will not be specially enumerated and described. Outcrops and indications of mica can be found in the townships of Eardley, Masham, Low, Denholm, Hincks, Aylwin, Wright, Northfield, Bouchette, Maniwaki and in the Pontiac division.

The more prominent mines in these districts are:—

TOWNSHIP OF HINCKS.

*Range II, lot 22.—This property produces a dark mica, but the crystals are of very large size. About 100 tons of this mica have been mined from a pit measuring fifty feet by twelve feet and thirty feet deep and there is a large quantity of this mica in sight. The property is situated about three miles from Aylwin station on the Ottawa, Northern and Western Railway.

TOWNSHIP OF WRIGHT.

Range A, lot 6.—Known as the *Chaibee Mine*. Was worked early in the nineties by the Lake Girard Mica System. On this property there are three openings showing the occurrence of two veins of mica. The country rock is a granite and the mica appears on the contact between this rock and pyroxene. The mica is almost black and is used for special purposes in electrical apparatus.

The property has recently passed into the hands of the General Electric Company. The main workings consist of a shaft seventy-five feet deep, with a drift at the bottom about eighty feet long which follows the mica along the contact. A great amount of prospecting work has been done all over the property and seven diamond drill bore-holes

have been sunk in the vicinity of the main deposit from 40 to 140 feet in depth. The mine is fully equipped with boilers and hoisting machinery and work can be started at any moment that there is a demand for this peculiar kind of mica.

*Range D, lot 15.—This mine, known as the *St. Antoine*, is situated eight miles from Gracefield station (Ottawa, Northern and Western Ry.) on a hill about 150 feet high and is one of the best producers of mica in the Ottawa valley. The property has been intermittently worked since 1891, when the proprietors, Mr. M. C. Guay and others, with a few men, took out about thirty tons of merchantable mica of very excellent quality. Work was then suspended until 1898, when operations were resumed on a somewhat extensive scale. A new boarding house was built and the following year the mine was equipped with a complete plant; fifty men were at work and a large quantity of mica was extracted and sent to the cutting establishments of the Sills Mica Co. at Ottawa. The main workings consist of an excavation 120 feet long, 30 feet wide and over 100 feet deep, near the contact of gneiss and pyroxene, where the principal deposit is situated. The mica occurs in bunches and pockets in a reddish and gray calcite in a width of from five to twelve feet and is of the usual amber quality. The property, as a whole, is a very promising one and deserves to be exploited to the largest possible extent.

Province of Ontario.

TOWNSHIP OF LOUGHBORO.

The principal mine in the province of Ontario is the *Lacey Mine*, situated about four miles from the village of Sydenham and comprising lot 11, concession VII of Loughborough, Frontenac county (Figs. 31 and 32). This mine is now the property of the General Electric Co. and no money has been spared to test its actual value. In the early years of its history it was a prominent producer of apatite, but the mica found in connection with this mineral was then not marketable. The main workings consist of a shaft 165 feet deep, from which branch six levels, of which the longest one is 200 feet. An air shaft has been sunk forty-five feet northwest of the main shaft, connecting with the fifty foot level. The shaft

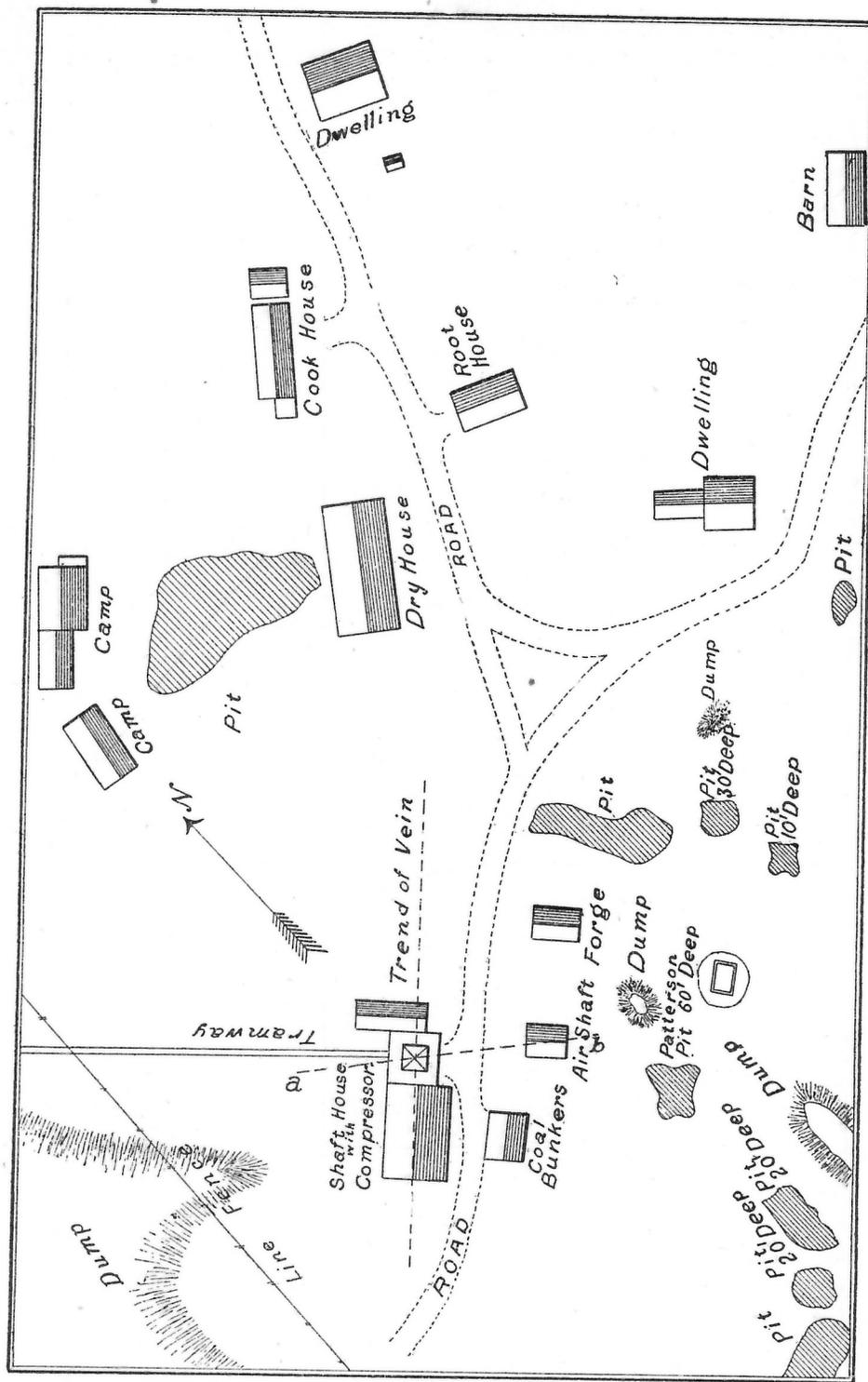

FIG. 31.—Surface Plan of Lacey Mine, near Sydenham, Ont.

mouth is timbered with a 6x6 foot collar 25 feet deep and with laggings over the remainder of the opening. The entrance to the underground workings is through the air shaft, where a system of ladders is installed. All these workings open up a large deposit of mica imbedded in a pyroxene rock with a main strike northeast-southwest. This deposit is very remarkable both on account of the large sized mica crystals found throughout the vein matrix and the peculiar character of the deposition of the mineral as a whole. While, in nearly all mica mines, either a contact or pocket deposit in the pyroxene may be distinguished, the Lacey mine makes an exception to the rule and it is difficult to say to what class this mine actually belongs. In some places underground the country rock, a gray gneiss, appears to form a contact, but in other corresponding places in immediate vicinity no such contact can be observed. This fact leads to the conclusion that the stratified gray gneiss observed at several places in the underground workings must be boulders or fragments of the country rock, which, in this case, cannot be far distant. From the dispersedness and the sporadical appearance of the mica in depth it must be conjectured that the deposit is composed of very erratic fissures running through a belt of pyroxene, the extent of which has not been fully established. Judging further from the nature and extent of the workings, especially in a northwest-southeast direction, where very large accumulations of mica were encountered, it appears that the mica-containing matrix takes the shape of a pyramid with sidelines diverging towards the depth. The rock generally met with in the workings is pale green pyroxene, then a pinkish calcite and finally apatite in crystals and little bunches. All the constituents of this filling being of a soft nature, only a small explosive power is needed, but for the same reason all the drifts require good timbering. The mica occurs, as a rule, in large crystals, but sometimes the sheets hold crevices parallel to the sides and break up in smaller pieces. A number of large sized crystals, occasionally measuring two to three feet in diameter and several feet in length, are generally grouped together and form a large pocket or accumulation of mica. An idea of the richness of some of these deposits may be gathered from the fact that one pocket alone gave 62,000 lbs. of clean mica. Most of the mica mined is of the large size and, so far as the writer knows, there is not another mine in Canada that yields such an amount of large sized crystals and sheets. One crystal, exhibited at St. Louis, is

said to measure more than five feet in diameter. Very often micaceous matter, in a ribbon-like structure, appears in the pyroxene. Apatite does not appear to occur in payable quantities, but pale green crystals are often seen imbedded in a matrix of a reddish soft calcite. Some of the mica from the Lacey mine investigated by the Smithsonian Institute at Washington has been pronounced pleochroic in an exceptional degree.

The formation surrounding the main shaft of the Lacey mine has been thoroughly tested and prospected by trenches, open cuts and even by diamond drilling, the thoroughness with which this work has been done giving evidence of the energy and skill displayed by the present management. The Lacey mine is another striking example of how a mine should be thoroughly tested before it is asserted that the property no longer contains productive mineral. Thorough investigation has proved the existence of large mica deposits in a southeastern direction from the shaft.

The shaft's mouth is covered by a forty foot head frame and solid structure containing the boilers, all machinery and a cobbing shed. Several new buildings, consisting of a boarding house to accommodate seventy-five men, drying room, etc., have been recently erected on the property. The mica is not trimmed at the mine, but roughly cleaned and sent to the works at Sydenham.

**Concession VIII, lot 12.—*Freeman's Mine*. Discovery of outcrops reported.

**Concession IX, lot 7.—The owner of this property is Mr. J. W. Trousdale of Sydenham. On being thoroughly prospected, a vein of fine mica crystals was laid open for a length of forty feet. It has been worked only on a small scale but the deposit appears to be a substantial one. On the adjoining property, lot 8 in the 10th concession, a shaft has been sunk 100 feet deep on a mica vein running between two well defined walls of country rock. This deposit is a contact vein, which shows a good deal of mica of the very best quality.

**Concession X, lot 6.—This property, situated four and half miles west of Sydenham, has been worked intermittently and is known as the *Gould Lake Mine*. Two shafts have been sunk on the property. Shaft No. 1 is on the west end of the lot and is 115 feet deep with a section of eight feet

**Report Ontario Bureau of Mines, 1902 and 1903.

by twelve feet. Drifts have been put in at the sixty foot level and at the bottom of the shaft and the mica has been stoped right to the surface. Shaft No. 2 is situated close to No. 1 and has a depth of eighty feet. The mica appears to occur in two vein-like accumulations and is of excellent quality. A great many other openings have been made all over the property showing more or less the occurrences of mica.

**Lot 7.—Known as the *McClatchy Mine*. An underlay shaft has been sunk to a depth of 100 feet, where it gradually widens to a chamber of eight feet by thirty feet, while its incline increases from 80° to vertical. Hoisting is done by horse derrick. A fine deposit of mica has been opened up.

Concession XI, lot 18.—Belonging to Mr. J. H. Roberts, is situated nine miles from Sydenham. Two vein-like deposits have been partly opened up on this property. On one an excavation, forty feet wide, is sunk near the contact with a gray gneiss to a depth of nearly 100 feet. Another deposit is opened up for a length of over 150 feet. Several outcrops of good mica can be noticed in different parts of the property. The mine is being worked on a small scale.

Concession XII, lot 2.—This property is owned by Mr. R. T. Hopper, of Montreal, and is situated three miles from Harrington station on the Kingston and Pembroke R.R. The development work consists of four openings at different points along a well defined lead of mica. Some eight tons of mica of excellent quality were taken out, some of the crystals measuring twenty-two inches across. There is also a deposit of pure feldspar on the property.

Concession XIV, lot 14.—Known as the *Birch Lake Mine*. A shaft has been sunk to a depth of 80 feet at an incline of 80° southwest along a deposit on the contact of the pyroxene and the country rock. The mica mined was of excellent quality.

TOWNSHIP OF BEDFORD.

Concession XII, lot 4.—Known as the *Stoness Mine*. Several shafts have been sunk on this property, one reached a depth of 425 feet at an incline of 25°. Drifts have been run at the 135 foot and 201 foot levels and the deposits

tapped have yielded a fine quality of mica. In the adjoining property to the west two shafts have been sunk to a depth of thirty and thirty-five feet. All the deposits so far worked are contact deposits in lines of fissures between pyroxene and granitic rock. In addition to the above workings, a great deal of prospecting work has laid open mica deposits of value.

TOWNSHIP OF NORTH BURGESS.

A large, productive mica field and one which promises well for the future is the country south of Perth in the township of North Burgess. A large number of these mica properties have been early apatite producers and some of them have developed into productive mica mines. The *Pike Lake Mine*, the *Martha Mine*, and the *Hanlan* and *Byrnes* mines are examples of this class and though operations on some of them have been temporarily suspended, there is no doubt that, judging from the past records, they will be reopened and will contribute considerably to the output of mica as soon as the market is in a better condition.

Concession V, lot 13.—The *Baby Mine*. Was worked up to 1897 for mica, but it appears that the mine was worked only for large size mica, the small sizes being stored away. Operations were again started last February by the new owners, Messrs. P. C. McFarland and J. J. Smith. The main shaft has a depth of 95 feet and is sunk on a solid mica vein which runs N.W. 60° near the contact with a syenite gneiss, running N.W. 25°. The vein on the surface is opened up for sixty feet, the average width being eight feet. At a depth of forty-five feet the length of the opening is fifty feet, narrowing down to twenty-five feet in the bottom of the shaft. The lead (Fig. 19) is well defined and consists mostly of calcite, a soft, pale green pyroxene, micaceous matter and mica crystals of perfect shape and quality. The mine is worked with a small plant, consisting of a 20 h.p. boiler, steam hoist, two derricks, one machine drill and a Cameron pump.

Concession VI, lot 11.—The *Hanlan Mine*, which is now owned by the General Electric Company of Schenectady, N.Y., has been extensively developed. The main workings consist of an open stope from the surface down, following the strike

and the dip of the vein, which runs north and south (dip 80° east) and forms a fine contact deposit between a belt of pyroxene and a gray gneiss. The depth of the shaft is 120 feet. There is a clear stope of 150 feet in the bottom. At fifty feet north of the main workings another pit was sunk some time ago to a depth of twenty feet and still farther north to the boundary line other outcrops indicate the continuance of the vein in that direction. To the south the vein can be followed for a distance of over 200 feet, at which point it is lost in a swamp. The mine has produced with a comparatively small number of men a large amount of mica; the daily output was from 1,500 to 1,800 lbs. of rough mica. Apatite is also met with in connection with the mica and is occasionally mined. The mine is equipped with a small plant. There is a large boarding and store house, stables, etc., and operations may be resumed at any moment. To the south of the Hanlan mine, about one-third of a mile distant, the old *Adams Mine* (lot 12 in Concession VI) has been worked to some extent by the same Company. A pit thirty-five feet deep has been sunk in a shattered zone of pyroxene, bordering the country rock. The mica is very much broken up and exhibits signs of crushing influences from movements of the formation.

Concession VI, lot 13.—The *Martha Mine* is one of the oldest mines in the province and has contributed considerably in its early days to the output of apatite. The main workings consist of a large open cut about 150 feet long, from twenty to thirty feet wide and 100 feet deep. The mica occurs in irregular lines of fissures in a pale pyroxene in the vicinity of granitic rock. This mine has yielded a very large quantity of mica and there is very little doubt that if operations were resumed the mine would produce just as much mica as formerly.

Concession VII, lot 11.—The *Byrnes Mine* is an old phosphate property and has been taken over by the General Electric Co. The mica found on this property is of a dark black colour, in marked contrast to any other mica found in the vicinity. The principal opening on this property is a long cut with a strike N.W. 40° in pyroxene along the contact with mica and hornblende gneiss; it is nearly 100 feet deep.

There are a number of openings, trenches, crosscuts, etc., all over the property and it appears that mica can be found throughout.

Concession IX, lot 17.—The *Pike Lake Mine* is the oldest mine in Ontario and has been worked for apatite as far back as thirty-seven years ago. It is located at a distance of half a mile southwest of Stanleyville and nine miles from Perth. This property, together with the Martha mine, were successfully worked some twelve years ago by the Lake Girard Mica System and subsequently by lessees until the year 1900. The works of the Martha and Pike Lake mines are now under water and no examination of them could be made.

In addition to the above properties there are, in the townships of Burgess, Loughborough, Bedford and Storrington a large number of places where mica occurs, but as the mode of occurrence is practically the same as described above and no important contribution is added to the total output, no further mention is made of them here. All these properties, however, are marked on the map accompanying this report.

Mica Cutting Factories.

There are altogether seven mica cutting establishments in Canada, six of them are located in Ottawa and one in Kingston. In busy times these factories give employment to approximately 800 persons.

The factories in Ottawa are operated by: The Laurentide Mica Company, The General Electric Company, Blackburn Bros., Wallingford, Munsell and Sills-Eddy and that at Kingston by Kent Bros.

The General Electric Co. employs at present a force of about 100 persons. The spacious building on Isabella Street covers an area of 10,000 square feet and is divided into a cutting and splitting department, stores and shipping room and offices. The machine cutting knives, similar to those described in another

chapter, are run by electricity furnished by the Consumers Electric Co. All the mica from the mines in the Ontario and Quebec section is shipped to this factory and is there prepared according to demand.

The Laurentide Mica Co. has recently occupied its new quarters on Duke Street. A new, solid, two story brick building contains all the departments for the employment of over 400 persons. All the cutting knives are run by electricity. The factory handles the output from the Company's mines in the Quebec division and employs at present 110 persons.

CHAPTER V.

STATUS OF THE CANADIAN MICA INDUSTRY.

PRODUCTION, EXPORT, MARKET AND PRICES.

Canadian mica mining was still in its infancy ten years ago. It has now assumed such proportions as entitle it to a prominent position amongst the mineral industries of the Dominion. In its early days mining was carried on in a spasmodic manner, that is to say, deposits were only tested superficially and as soon as a little dead rock threatened to cut off the mica the mine was abandoned. Many of the smaller producers worked intermittently, taking out the mica which outcropped on their farms and stopping work with the falling market or when the deposits were, in their opinion, exhausted. These erratic methods, and constant shifting of operations from one place to another proved altogether too expensive. A new era has set in, a more practical system has been adopted and development work in mica mines is now pursued in depth. And further, while formerly the mica industry was in the hands of individual operators, having in most cases only a very limited amount of capital at their disposal, today powerful companies owning extensive areas of mica lands have started operations on a large scale. To these companies is due the erection of substantial cutting establishments in the centres of the mica districts. These large concerns, realizing the immense importance of the qualities exhibited by the Canadian mineral, begin by testing their properties in the most systematic manner, both by the use of the diamond drill and by exploration work on the surface. There is no doubt that a great many properties, either on account of the lack of experience or unscrupulous manipulations of the operators, have been condemned and abandoned, whereas they should, with efficient and honest management, have continued to yield a large and profitable output. The machinery installed by the large companies, compared with that of former years, is of a more substantial nature and is erected with a view to deep sinking and extensive operations. Large sums of money have thus been spent in advance of actual production.

Formerly when deep shaft mining was attempted, all the mica within reach, practically all that was visible, was mined without a thought being given to reserves, but in the last few years several mines, especially those in the Ontario section, real-

izing the immense importance of such an ore reserve in case of a sudden exceptionally large demand for mica, have carried on operations with this important object in view and the result is that these mines have now large reserves ready to be stoped at any desired time. The advantages of such a policy are obvious.

As to the future possibilities of the productive mica fields of Canada, there is no doubt that the future outlook for the production of a large tonnage is very bright and if Canada should ever be called upon to furnish the world's supply the mica fields of Ontario and Quebec could soon be prepared for such an emergency.

There are at present employed in the mica industry 550 persons, but nearly all the mines and mica-cutting establishments are only employing about half the usual number of persons owing to the temporary slackness of the demand, probably due to last year's over-production. For instance, the General Electric and Laurentide Mica Companies usually employ in each of their cutting establishments over 300 hands, whereas at present they employ only half that number. The same remark applies to the larger mines like the Lacey, Blackburn, Wallingford, Laurentide and others. The wages paid last year amounted to a total approximately of \$120,000. It is estimated that the total outlay for plant, including buildings and all accessories, employed in the mica industry amounts to approximately \$160,000.

PRODUCTION, EXPORT AND MARKET.

The following statistics of production are taken from the reports of the Geological Survey of Canada.

VALUES OF YEARLY PRODUCTION.

1886	\$ 29,008	1895	\$ 65,000
1887	29,816	1896	50,000
1888	30,207	1897	76,000
1889	28,718	1898	118,375
1890	68,074	1899	163,000
1891	71,510	1900	166,000
1892	104,745	1901	160,000
1893	75,719	1902	242,310
1894	45,581	1903	176,334

The total value of the mica produced in Canada up to the beginning of 1904 is placed at approximately two million dollars.

Most of the mica is absorbed by the United States, which placed a duty of twenty per cent. *ad. val.* and six cents per pound on thumb trimmed mica. Efforts have been made in recent years to create a market for the Canadian mineral in England in competition with the East Indian product and the statistics furnished

by the Department of Trade and Commerce show that Great Britain has commenced to take a large part of our production.

EXPORTS OF MICA.

Year.	To	To
	United States.	Great Britain.
	lbs.	lbs.
1901.....	761,991	211,833
1902.....	868,645	115,388
1903.....	729,489	653,081

PRICES.

Muscovite.

Prices for commercial muscovite fluctuate considerably, depending on the transparency and perfection of the sheets.

A dealer quotes the following prices for medium quality Canadian muscovite:—

1" x 3" thumbtrimmed, per pound.	12 cents.
2" x 3" " "	25 "
2" x 4" " "	40 "
3" x 5" " "	75 "
4" x 6" " "	100 "

Phlogopite.

The prices paid for Phlogopite of the different sizes naturally fluctuate considerably and much speculation is manifested amongst mica dealers. The following table gives the present prices paid by a large firm:—

Size. 1" x 3",	10 cents per pound, thumbtrimmed, (not cut)
2" x 3",	22 " " " "
2" x 4",	30 " " " "
3" x 5",	55 " " " "
4" x 6",	75 " " " "
5" x 8",	100 " " " "

In this connection it is interesting to note that Sir William Logan in his report of progress for 1863 mentioned a sale in London of several hundred weights of large, selected mica crystals, taken from a locality north of Burgess, and fit for splitting into thin plates. The price was two shillings per pound, while from four pence to seven pence was given for inferior qualities. There was also a large demand for smaller sizes and for the refuse. The former, among other uses, was employed in making letters for window signs. Ten shillings a hundredweight was offered in London for fifteen or twenty tons of such material.

CHAPTER VI.

COMMERCIAL APPLICATIONS OF MICA.

The perfect cleavage of mica, yielding thin, smooth, transparent sheets of great flexibility and elasticity; its chemical stability and above all its non-conductivity are physical properties which no other mineral unites to the same extent. Mica has been an article of commerce for several hundred years. The aboriginal Indians of America were apparently acquainted with the mineral and have left traces of their search for it. It has been frequently found in the graves of Indians east of the Mississippi and the fact that it has been found in localities where it does not occur furnishes evidence that intercourse must have prevailed between widely separated tribes. In India, also, the natives have for centuries applied mica to industrial purposes.

Use in Windows and Lanterns.—The earliest use of white mica was undoubtedly for lanterns and windows. In the early stages of glass making, when the process for annealing plates had not been invented, mica was specially used in cases where the windows were liable to sudden shocks or violent vibrations, as, for instance, in the windows of warships. After the perfection of the process of glass annealing, mica was forced into the background. In lanterns mica has been replaced by glass and in some instances by horn, but in circumstances where breakage entails considerable risk mica is generally retained.

Mica for Glasses and Spectacles.—The best employment of the immense quantities of scraps and fragments of waste mica is the substitution of mica for glass in spectacles worn by workmen, especially stone and metal workers, to protect their eyes from chips and splinters. As made in Germany, these mica glasses are about one-twenty-fifth of an inch in thickness. The advantages gained by their use are greater than would at first be imagined. Mica spectacles cannot be broken. Pounding with a sledge hammer merely flattens them, nor does molten metal poured on the mica materially affect it. The shower of pointed iron particles which issues from lathes merely rebounds from the elastic mica glasses.

Fire Screens.—In consequence of its transparency to light but not to the same extent to radiant heat, we find mica employed as fire screens and as covers for peep holes in furnaces, permitting the observation of the processes in highly heated furnaces without inconvenience.

Stoves.—No artificial transparent substance has as yet been devised that possesses the utility of this mineral where intense heat or sudden changes of temperature take place. It has, therefore, considerable use in anthracite stoves, where it is desirable to obtain the cheerful glow of the fire without the direct heat. Its transparency is little affected by the repeated and alternate heating and cooling and it is not readily attacked by most of the gases and vapours. It does not, however, so effectually resist the attacks of the gases from a bituminous coal and it is, moreover, so quickly blackened by the soot that it soon loses its transparency. Its use, therefore, is confined to anthracite or to gas-asbestos stoves.

Lamp Chimneys.—Chimneys for oil and gas lamps with round burners are sometimes made of mica, especially those outside show windows, where glass would not stand rain-drop splashes or sudden changes of temperature.

Mica in Miners' Lamps.—In order to avoid breakage of glass in an ordinary miner's lamp, Mr. Max Raphael, of Breslau, Silesia, has constructed a cylinder of double plates of mica, each of which has its vertical edges united in metal to form a secure joint. The smaller of the two cylinders is enclosed within the larger and this leaves a small annular air space of about three-tenths of an inch. The two vertical joints coincide so as to intercept as little light as possible, although this may be a disadvantage as regards strength of construction. The top and bottom of the two cylinders are kept in position by two brass rings with annular rims, the edges of which are turned towards one another. The grooves thus formed contain some red-lead cement, in which the edges of the mica cylinders are imbedded, thus ensuring air-tightness. It forms with the lamp cage a light, compact and, what is important in coal mines, an almost unbreakable lantern. These advantages are not gained without a slight diminution of light for mica is not so transparent as glass, but this objection is counterbalanced by the increased security.

Paints, Wall Paper and Ornamental Uses.—Another use for mica is its application, when previously coloured or metallized, to ornamental purposes. Its unalterable and diaphanous nature helps to preserve gilding, silvering or colouring from deterioration. Finely ground mica also shows handsome effects and when mixed with a solution of gum-arabic it makes a good silver ink. The gelatine combination is used for inlaying buttons. Another

application of mica is in the production of those beautiful bronze-like colours which bear the names "brocades," "crystal colours," and "mica bronzes." Some of the advantages these possess are lightness of weight, indifference to sulphurous exhalations, and occasionally, a brilliance surpassing even the metal bronzes. When small particles of muscovite are spread over articles coated with asphalt varnish, the result is a good imitation of granite. The crystal colours are also suitable for calico printing and fabrics to which they are applied exceed in brilliancy the heavy bronze and glass dust fancy fabrics of Lyons. Such colours have been used to decorate porcelain and glassware, the articles undergoing a second heating up to the fusing point of their glazing. By suitable dyes the material is coloured in a variety of hues.

Muscovite mica is white, more or less transparent, and has a gloss similar to silver. It does not spread easily when ground and needs a groundwork. Therefore, if a silver gloss is wanted, the ground has first to be laid in with clear, white distemper. After the distemper is dry, it should be glazed over once or twice with a solution of the liquid mica and water in equal parts, a soft camel's-hair brush being used. The liquid mica assumes the colour of the distemper used; the same colour should be applied to the groundwork.

In the days of ancient Rome it was the custom to scatter the powdered material over the surfaces of the amphitheatre to obtain a brilliant glistening effect. In India it is used at native festivals and in the Mohammedan religious services for processional ornaments, such as lamps, punkhas and decorations on banners. Coloured micas have been suggested as a substitute for coloured glass, but their large proportion of iron renders them susceptible to oxidation when exposed to the weather. There seems to be no reason, however, why amber coloured mica as well as the muscovites with inclusions of magnetic oxide disposed in regular patterns might not be used in unexposed places. The natives of India, especially in the Madras presidency, sell large numbers of pictures and portraits painted on mica sheets of various sizes.

Utilization of Mica Waste.—The utilization of mica waste has become an important factor during the last five years. There are several firms engaged in this industry, the products being sold in different grades. Some of these are used for steam and water valve seatings, whilst the poorer qualities are used as additions to fertilizers, helping them, it is said, to retain their moisture.

In consequence of this property it has been used as an absorbent for nitro-glycerine in the manufacture of one of the forms of dynamite. The poorer grades of mica are also successfully employed in the manufacture of lubricants for railroad purposes. It is claimed that with its use hot journal boxes are impossible. For the production of these grades an extensive factory has been established in Denver, Colorado, and the process employed is as follows:—

The mica comes to the factory in carloads just as it is taken from the mine. It is fed by boys into two machines which cut it into fragments about half an inch square. By a system of pneumatic tubes the mica so cut is delivered to the atomizing machines which grind it into powder. Each machine consists of two steel shafts three feet long, with a series of spirally arranged beaters of gun-metal, which revolve in a close case. These machines make from 5,000 to 7,000 revolutions per minute. The fingers on one shaft run between the fingers on the other, so that when the material is passed through the pneumatic tubes from the feeding machine to the atomizers at a velocity of 15,000 feet a minute the work of atomizing is instantaneous.

The mica, now reduced to minute particles, continues its course at the same velocity through another set of pneumatic tubes to the sizing bins. Here the current is so retarded by a special mechanism that it causes the material to settle, according to its fineness, in the various compartments, of which there are six. Compartments containing the graded mica powder rest upon hoppers or bins immediately over the mixing pans. Into the latter the several grades of mica powder are drawn and by means of mechanical mixers, with which the pans are provided, treated with the proper percentage of oils and other ingredients.

Directly over the hoppers are located the oil tanks, which supply the mixers by a pipe running down the outside of the hopper, at the end of which is a faucet.

At one end of the bins is the "dust arrester," a cylindrical machine four feet in diameter and ten feet high. Any of the material too light and fine to settle is driven into this machine by air currents and is drawn off as needed.

It is stated that before this machine was invented no other pulverizing machine had a capacity of more than three or four hundred pounds a day and that the material was not sufficiently fine for lubricating purposes. It is claimed for this concern that

it can pulverize about five tons in a day of ten hours and that it turns out an excellent lubricant.

Uses in Electrical Apparatus.—The most extensive use of mica, especially of the Canadian amber variety, is for electrical insulation. In fact it is these applications which have made the mica industry what it is today. Regarding the qualities of mica for electrical purposes, an expert in the mica trade gives the following opinion as to the requirements of commercial sheet mica*:
 “Sheet mica must split easily, that is, make a clean separation of its laminae without cracks and tears such as occur when hard, brittle mica is split. It must be flexible and soft. Nearly all mica is soft enough to be scratched with the finger nail, but this test is not sufficient. In general, sheets of mica which show a smooth surface are softer than those which show blemishes or corrugations when split.”

The most valuable property of Canadian mica is its electrical non-conductivity. Its market value is based on its freedom from streaks and iron stains.

The relamination as effected in micanite is said to improve the insulating power of the mineral. Micanite is also claimed to have greater flexibility than the sheet mica from which it is made, the cement used in it softening with heat and permitting the sheets to conform without cracking to the curved surface to which it may be applied. Upon cooling it retains the same position and becomes so dense as to emit a metallic sound when struck.

The insulating power of mica is superior to that of any other substance applicable to armatures. Of special advantages are its evenly laminated structure which permits its ready intercalation between the copper-pole pieces of the commutator and its hardness which prevents it wearing away too rapidly under the action of the brushes. The highest temperature to which an armature is subjected even by short circuits or bad construction will have no injurious effect on mica. Colour does not seriously affect the utility of mica in electrical machinery, but the presence of magnetite inclusions affecting its insulating qualities renders it useless for this purpose. Some 450 different patterns are used in the electrical application; they are cut from the natural sheets or from the micanite already described.

The insulating qualities of mica are impaired by contact with oil. This has been demonstrated by Mr. P. O. Maloney,** an

*“Mineral Industry” for 1898, page 506.

***Electrical Review*, 1901.

electrical engineer, by the following experiment: A piece of the best Indian mica was placed between two planed surfaces and withstood an insulation test of 16,000 volts. The current was then removed and the surface of the mica lightly coated with paraffin oil. Under this condition it was found that it would break down at 9,000 volts. Another piece of Indian mica tested at lower voltages and under the same conditions as above was found to withstand 8,000 volts and, when oil was applied, to break down at 4,000 volts. An alternating current was employed in these experiments.

In comparison with the East Indian mica the Canadian product seems to hold its own and, in several respects, is even superior. The late Dr. George Dawson having sent samples of the Canadian phlogopite to the Imperial Institute, London, to ascertain their commercial value and the possibility of an extension of trade in the United Kingdom, Professor Wyndham Dunstan, M.A., F.R.S., Director of the Scientific and Technical Department of the Imperial Institute, reported as follows:—

“General, physical and chemical examination showed that
“the samples were uniform in character, pliable and softer than
“much of the mica which appears on the English market. In
“order to ascertain its commercial value, especially its fitness for
“electrical purposes, the samples were submitted to one of the
“largest electrical manufacturers in London and also to one of the
“largest mica brokers in the city.

“The electrical manufacturers report that the mica is suitable
“for a variety of electrical purposes. On the general question of
“the uses and comparative value of the Canadian amber mica the
“brokers remark that this variety of mica is of no value other
“than for electrical purposes, its special value being princi-
“pally due to its softness and easy lamination. They are
“of opinion that the Canadian amber mica is of greater value
“for electrical work than most of the Indian mica that comes to
“this country. They remark, however, that there are two or
“three varieties of Indian mica, such as White Bengal, Cochin
“from the west coast of Madras and Ceylon amber mica, which
“compare very poorly with the Canadian product, whilst the
“selling prices of these Indian varieties are often from one-third
“to one-half those asked for the Canadian mica. They confirm
“the opinions expressed in Dr. Dawson’s letters of February 16th
“and April 4th (1901) that Canadian miners obtain a better price

“in the United States than in the London market, chiefly from the circumstance that American electricians prefer the Canadian product, which is close at hand and can be depended upon for uniformity of quality and regularity of supply.”

Although circumstances point to the United States as being the natural outlet for Canadian mica, it would, nevertheless, be worth while to make it better known in the British market since there are several factors operating against the Indian product, the principal of which is the irregularity of supply.

Use of Scrap Mica for Boiler Coverings.—Some five years ago mica waste was first used in the manufacture of mats for boiler coverings. Formerly boilers, in order to retain their heat, were covered with a coat of cement, which would break in the course of time, and which would not permit of an inspection of the outside boiler plates without the removal of such coating. Now, so called fire proof mica mats are used, which can be attached in sections to a boiler by means of hooks and iron bands. They consist of a galvanized iron netting in which corrugated thin mica plates are fastened, the object being to increase the superficial area without correspondingly increasing the weight. The more finely these flakes are divided, the more effective they become. Each one is in itself a splendid non-conductor, so that the highest results in the way of checking the escape of heat waves are obtained by the greatest number of flakes.

These mica mats have not alone proven very efficient as heat insulators, but have been found to be very durable; mats, after several years of constant use, have been found in perfect condition. This is the more gratifying since there is no severer test to which a boiler covering can be subjected, on account of the constant heavy vibration. Mica waste is also made into sectional coverings for steam and hot water pipes.

Since mica will stand almost incandescent heat without injury, it is very valuable as a protection from fire. Considerable quantities of it have already been used for protecting smoke flues, kilns, etc., and in some factories the fire underwriters have reduced the premium after the flues have been protected with mica.

Mica Insulation for Steam Pipes and Boilers.*

The loss of heat from the surfaces of steam boilers and steam pipes has a money value which is not always realized. Particu-

*Reprinted from *Engineering*, 1901.

larly is this the case in electric stations and other places where steam pressure is maintained always, without intermission at nights and on Sundays. Professor Silvanus Thompson has stated that heat equivalent to 1 horse-power is lost for every 66 lineal feet of 4-in. uncovered pipe, the steam pressure being 100 lbs. Assuming 27 lbs. of water and 3 lbs. of coal per horse-power hour, each square foot of uncovered surface would dissipate in a year the heat from 3,716 lbs. of steam, or from 398 lbs. of coal. Professor Capper, of King's College, London, has published that a square foot of uncovered steam pipe condenses 1.516 lbs. of steam per hour, at an absolute pressure of 259 lbs. per square inch. This corresponds to 13,272 lbs. of steam per annum, or to 1,474 lbs. of coal, reckoning 9 lbs. of water to a pound of coal.

At University College, Professor Hudson Beare found 0.878 lbs. of water condensed per square foot of bare pipe per hour at a steam pressure of 86 lbs. per square inch, 0.775 lbs. at 59 lbs. pressure, and 0.376 lbs. at 3 lbs.; these figures corresponding to 7,681 lbs., 6,789 lbs., and 3,283 lbs. of steam per annum, and to 853 lbs., 754 lbs., and 365 lbs. of coal. Another test by him gave the following results:—

Steam Pressure.	Pounds of Steam Condensed per Square Foot of Surface.		Coal per Year.
	Per Hour.	Per Year.	
lbs.	lbs.	lbs.	lbs.
47	0.622	5,448	605
80	0.784	6,867	763
160	1.011	8,847	983

Mr. J. Zulauf, at St. Petersburg, experimenting with steam of 10.3 to 10.7 kilogrammes per square centimetre pressure (145 lbs. to 152 lbs.), found that 5.344 kilogrammes of water were condensed per square metre per hour (1.1 lb. per square foot). This is equal to 9,636 lbs. of water per annum and 1,070 lbs. of coal.

On May 24, 1889, we published the result of experiments by Mr. Albert Haacke. In these, the steam pressure being 60 lbs., 1 square foot of bare surface condensed 0.66 lb. of steam per hour, or 5,808 lbs. in a year. On August 19, 1898, we published an abstract of a paper, read by Mr. Charles L. Norton before the American Society of Mechanical Engineers, on the "Protection of

Steam-Heated Surfaces." In this paper the result of many experiments gave the loss per square foot of surface at 13.84 British thermal units per minute at 200 lbs. pressure, and 8.92 British thermal units at 100 lbs. pressure. Taking the latent heat of steam at 200 lbs. as 840 deg., each square foot of pipe therefore condensed 1.01 lb. of water. At 100 lbs. pressure the condensation was 0.6 lb. per foot. It must be remembered, however, that these experiments were not made with steam, but with hot oil. We have put these various results in the form of a diagram, in which the ordinates are pounds of water condensed per square foot per hour, and the abscissæ are temperatures, the corresponding steam pressure being also marked (Fig. 1). The points lie fairly well on

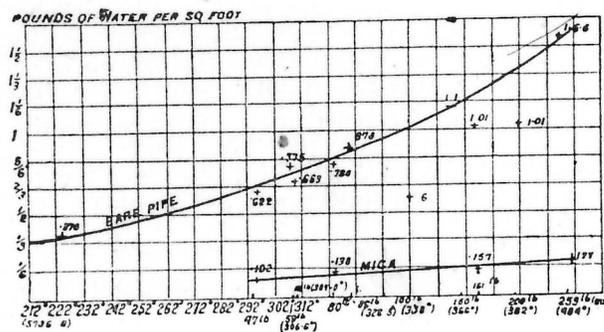

FIG. 1.

a curve, considering that we have taken no note of the atmospheric temperature. The two American results, however, in which, as already explained, the heating medium was oil and not steam, lie apart from all the others. The reputations of Professors Capper and Hudson Beare are sufficient to cause these figures to be accepted, but it is satisfactory to find that they confirm each other. In all cases the steam was stationary in the pipes; experience suggests that if it had been flowing rapidly the loss would have been somewhat greater.

As it is, we find that with steam at 212 deg. Fahr. each square foot of unclothed surface condenses 2,920 lbs. of steam per annum, requiring 324 lbs. of coal for its evaporation. With steam at 245 lbs. (259 lbs. absolute) each square foot condenses, 13,272 lbs. of steam requiring 1,474 lbs. of coal. Intermediate pressures can be measured off the diagram, which will probably interest many steam users who had never calculated how much of their coal went to keeping the engine and boiler-room uncomfortably hot.

Those who are situated in towns, and have to burn expensive coal in order to avoid visits from the smoke inspector, will find special food for thought. At the very usual pressure of 150 lbs. per square inch, and with coal at 20s. a ton, each foot of uncovered pipe costs 9s. 6d. per annum. Even in the best-managed establishments, especially in electric-lighting stations, there are many feet of bare iron in flanges and valves which it is impossible to clothe, and which take constant toll of all the coal which comes into the place.

Of course, there are very few places in which bare steam pipes are tolerated. Almost invariably they are lagged in some way or other; for years there have been on the market many materials which are effectual in retarding the flow of heat from the steam to the atmosphere, although none stop it completely. It is interesting to learn how far they reduce the money loss.

From Professor Capper's report, which we have already alluded to, we find that he continued his experiments with four different kinds of well-known non-conducting compositions, and that with these the steam condensed per square foot of cooling surface per hour was:—

	Thick. In.	Lbs.	Per Cent.
Bare pipe.....	—	1.516	100
A.....	1.6	0.420	27.7
B.....	1.25	0.399	26.3
C.....	1.4	0.208	13.7
Mica.....	1.6	0.177	11.67

Evidently, three-quarters of the loss can be readily saved by lagging the surfaces, while 90 per cent. of it is prevented by using mica insulation. These figures are borne out by tests of various kinds of asbestos non-conducting covering, made by Professor Hudson Beare. In five samples the saving varied from 66½ to 75 per cent., while one other material gave an economy of 78½ per cent. Experimenting with mica insulation, he got the following results, which can be compared with the Table on page 92, and also seen on the diagram, Fig. 1:—

Steam Pressure.	Steam Condensed per Square Foot of Surface.		Coal per Year.
	Per Hour.	Per Year.	
lbs. 47	lbs. 0.102	lbs. 893	lbs. 99
80	0.138	1,208	134
161	0.157	1,375	153

The general result is, that while bare pipe involves a loss, under the conditions we have stated, of 9s. 6d. a square foot per annum, this can be reduced to about 2s. 6d. by the use of many of the efficient boiler coverings in the market, and to 1s. 4d. by mica insulation. In a place having a large area of steam-heated surfaces, say, 5,000 square feet, the usual loss will be about £600 a year. It would be quite justifiable to spend a large capital sum in order to reduce this by one-half.

The mica boiler covering referred to in the Table above was first introduced in Canada, and has been extensively tested there. We have before us the record of a series of trials, issued by Mr. R. Atkinson, mechanical superintendent of the Canadian Pacific Railway. In these, tanks about 14 in. cube were filled with water, which was then boiled, and afterwards allowed to cool down, the rate of cooling being noted. In one case the tank was bare, and in the other case lagged with (1) asbestos compound; (2) magnesia blocks; (3) wood lagging and air space; (4) asbestos and wood; and (5) mica. The following Table gives the results:—

	Loss in Five Hours.	Temperature at end of Fifth Hour.	Mean Temperature during Fifth Hour.	Difference between Tank and Atmosphere.	Loss in Fifth Hour.	Loss in Fifth Hour per Degree of Difference of Temperature.
Bare tank	deg. 84	deg. 128	deg. 133½	deg. 55½	deg. 11	deg. 0.198
Asbestos compound	53	159	163½	85½	9	0.105
Magnesia Blocks	33½	178½	181½	103½	7	0.0674
Wood lagging and air space	33½	178½	181½	103½	7	0.0674
Asbestos and wood	30	181	185	107	6	0.056
Mica	20	192	194½	116½	5	0.0428

The mica does not excel in this test to the extent it does in Professor Capper's, but still it is easily first.

The Grand Trunk Railway of Canada made what is the largest

test of non-conducting coverings ever attempted. Five full-sized locomotives were taken, and were lagged with different preparations. Steam was then raised in all the boilers simultaneously, and the fires were withdrawn when the blowing-off point was reached. The falling pressures, after the removal of the fires, were noted on accurately calibrated recording gauges, and the temperature of the air registered on recording thermometers. The experiments in every case were repeated several times, and the mean of the different readings were plotted in the curve (Fig. 2).

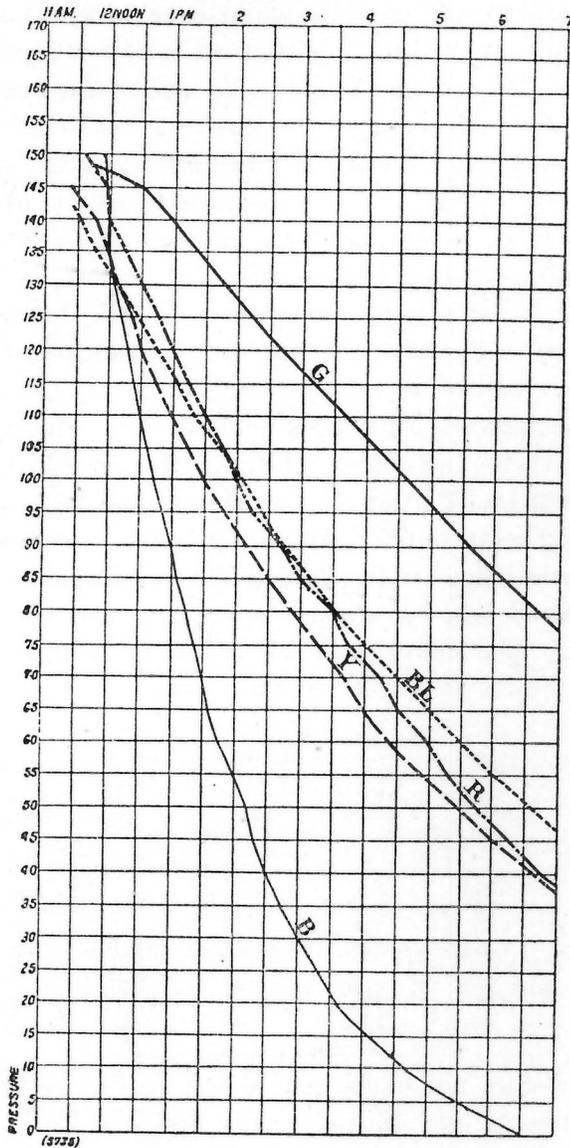

FIG. 2.

The original diagram extends over twenty-two hours, by which time the steam was completely down in every instance except two, and in those it was below 10 lbs. We have, however, only reproduced the first seven hours, as the chief interest centres at that end of the diagram. The coverings were (B) none (naked boiler), (Y) Grand Trunk standard covering of wood and asbestos paper, (R) magnesia, (BL) silicate cotton, and (G) mica. One set of experiments was made with an atmospheric temperature of 20 deg. Fahr., and the other at 50 deg. Fahr. The mica covering was only tried in the latter condition, and it is only these we have reproduced.

The loss of heat during the first hour is given by the following table:—

	Bare Boiler.	Standard Wood and Asbestos Paper. Covering.	Sectional Magnesia Blocks.	Mica Loco- motive. Lagging.	Silicate Cloth.
Pressure, pounds per square in.	lbs. 150	lbs. 145	lbs. 148	lbs. 148	lbs. 140
Loss of pressure in one hour. . .	56	20	13	6	24
At 7,000 lbs. water in boiler. loss of heat units in one hour.	231,000	73,500	46,900	21,400	77,000
Percentage of gain over the standard wood covering.			36.19	70.88	

These results show the mica as saving about 92 per cent. of the heat radiated from a bare boiler, and as being twice as efficient as sectional magnesia blocks. The figures of British thermal units have probably, however, only a comparative value, as the heat in the metal of the boiler is not taken into account; and although the specific heat of the metal was small, yet the weight of the boiler was many times that of the water.

Mica was first used as a covering for steam-heated surfaces in Canada by Mr. Michell, and is now being sold in this country by the Mica Boiler Covering Company, Limited, of 219 Gresham House, Old Broad Street, E.C. It is made up into flat and curved mattresses, enclosed between covers of wire netting, sewn with wire. For small pipes it is moulded to form, and enclosed within textile covers. As everyone knows, it is indestructible by heat, and it does not disintegrate into fine particles which pack into smaller bulk, as does slag wool. One has only to look at a sample of lagging to understand the cause of its great resistance to flow

of heat. The continuity of the wall, across which the heat must flow, is broken at a thousand places, and at every one of those the flow is impeded. The minute flakes of mica are laid in parallel planes, transversely to the direction of flow of the heat, without any cement, or adhesive, to connect them together. The heat, therefore, on emerging from one flake has to cross an air space to enter the next flake. Here it encounters the surface resistance which is always found when heat travels from a gas to a solid, and *vice versa*; it then passes through the mica, which is a very poor conductor, to find a second surface resistance at its posterior face. This series of operations has to be repeated hundreds of times between the steam pipe and the external air, with the result that the flow of heat is exceedingly slow. The mica used is to be found in large quantities, and hitherto has been a waste material.

CHAPTER VII.

MICA IN FOREIGN COUNTRIES.

Canada is the only country in the world which produces the phlogopite or amber variety in paying quantities. Reports have come from Australia, South Africa and the German possessions in Southwest Africa that phlogopite mica has been found, but up to the present no actual exploitation has been made to ascertain their real value.

The muscovite variety, however, which has been mined in Canada in only a very limited way, occurs in many countries, principally in the United States and India.

UNITED STATES.

In the United States the mining of mica is mainly confined to the States of New Hampshire, North Carolina and Dakota; although there have been a great many other deposits discovered the quantity of mica coming from these sources is insignificant.

In *New Hampshire* the most important producers are the mines at Grafton, Danbury and Alstead. According to A. Hoskins,* the old Ruggles mine in Grafton has produced mica for over 100 years, yielding an aggregate of over eight million dollars worth of mica. This mine at one time furnished four-fifths of the total consumption in the United States. Owing to litigation which has extended for over twenty years, the mine has not been worked to its greatest capacity, no machinery of any kind being in operation and drilling is done by hand. The crystals are split into sheets an eighth of an inch thick and the rough edges trimmed with a knife. The dealers cut it into the different shapes and sizes required by the manufacturers of electric machinery.

At Danbury there are two mines in operation, one, owned and operated by the Empire Mica Co., being considered a good paying mine. The quality of this mica is excellent, it being free from spots and very clear. In Alstead there are three mines in operation: the Davis, the Hoskins, and the Warren French mine. The Davis mine is a large producer and is considered one of the best paying mines. The mica is trimmed and shipped to Boston.

*Mineral Industry, 1899, page 507.

The other mines are reported to deliver a very good quality of sheet mica, while a large quantity of scrap mica is also produced.

In *North Carolina* the principal mica deposits occur in Mitchell, Yancey, Jackson, Haywood and Macon counties. Most of the many mines are working on a small scale. The mica constitutes about 1% to 10% of the pegmatite veins.

In *South Dakota*, Custer county, the Black Hills Porcelain, Clay and Marble Co. operates several mines. In the beginning of 1903 this Company shipped thirty tons of mica. The Crown mine, owned by the Chicago Mica Co., covers forty acres in Custer county and is regularly shipping mica (mostly for grinding) to the Company's plant at Indiana.

Dr. E. A. Smith reports a discovery in Alabama in the northwestern part of Randolph and the adjacent parts of Cleburn and Clay counties. The mica occurs in veins of a coarse grained granite, in which the constituents assume large proportions, often forming masses of a foot or more in size. The mica "boulders," as they are locally termed, deliver sheets of large size and excellent quality.

BRAZIL.

In Brazil, according to H. Kilburn Scott,* mica occurs in workable quantities in the States of Goyaz, Bahia and Minas Geraes. In the State of Minas Geraes the mica is found in pegmatite veins (Fig. 33), lenses or dikes in metamorphic schists near the city of Santa Luzia de Carangola, the veins running parallel to the Cayama and Papgais mountains. The deposits are generally altered to kaolin and vary in width from twenty inches to ten feet. There are about six mines which have supplied mica for export, but only two of them, the Fonseca mine and Coronel Seraphino, have been worked regularly. The Fonseca mine has produced about thirty tons of trimmed mica; the larger portion was used for lamp chimneys. The total output of the Seraphino mine is estimated at twenty tons. About fifty per cent. of this output has been obtained in sheets of over six inches in length. The approximate cost per ton of mica delivered at ports in the United States or Europe is \$309.00. On account of its great transparency and the absence of any spots, the Brazil mica is considered the finest on the market. It is largely used for ornamental purposes.

*Mineral Industry, 1902, page 467.

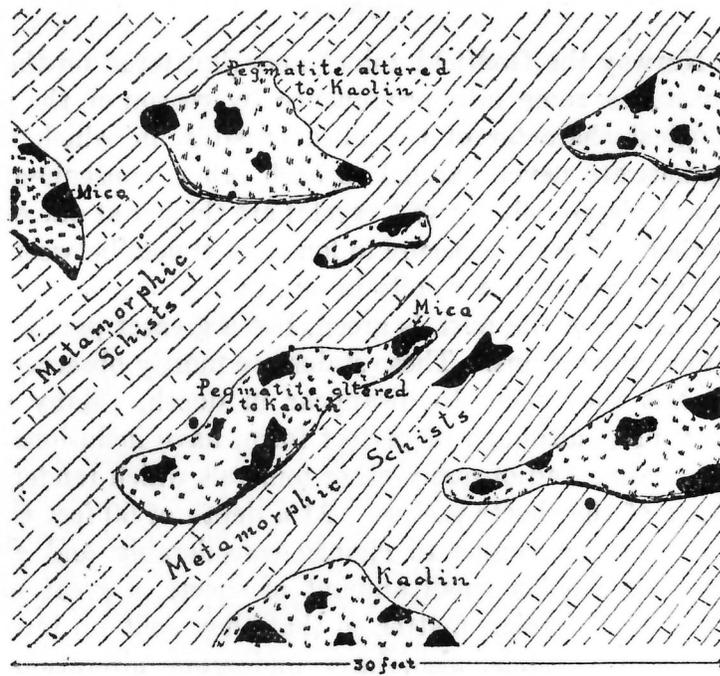

FIG. 33.—Mica Deposit at Minas Geraes, Brazil.

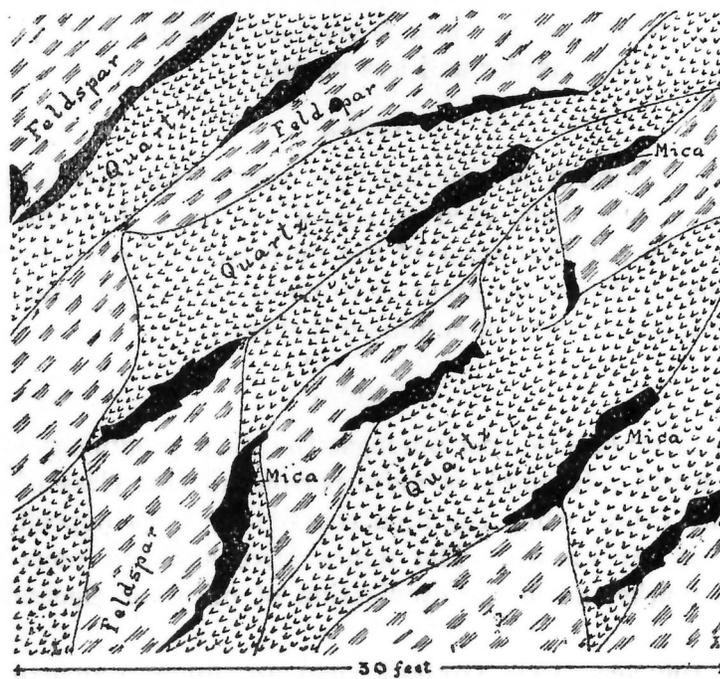

FIG. 34.—Mica Deposit at Godfjeld Mine, Norway.

NORWAY.

In Norway the Godfjeld mine* near Skutterud on the southwest coast has come into prominence by reason of the peculiar mineralogical character of the mica crystals, in which the two basal planes are never parallel to each other, consequently, the majority of plates split out of a crystal are thicker at one end than at the other. The mica occurs in lenses or shoots between quartz and feldspar (Fig. 34) or wholly in quartz.

The colour of the mica is green, but a greater part is brown, due to numerous stains. These stains are mostly observed on the surface, but they seem to disappear in depth. Many crystals from this mine, although of perfect form, have inclusions of garnets, tourmaline and of many other minerals which render a large percentage of the sheets useless. At a depth of 60 feet the character of the mica begins to change considerably and although these crystals yield a small amount of sheets, a great many of them are full of foreign matter so that they split up into flakes. A good many crystals, also, have undergone alteration into a greenish steatitic substance. This substance is in places compact, while in others it becomes earthy, occasionally fibrous and silky and it hardens shortly after exposure to the air. The mica when it is first taken from the mine is very soft, but after a few months it becomes much harder and less pliant.

CHINA.

From China it is reported that vast untouched deposits of mica have been discovered at Kiao-Chau bay. Nothing further is known except that some of the mica is discoloured by foreign substances. The veins are said to be up to ten feet wide and to contain a fair amount of commercial sheets.

INDIA.

India ranks foremost amongst the mica producing countries of the world. It employs more persons in this class of mining than any other, while the area covered by mica deposits is the largest so far known. The mines have supplied most of the world's market since the application of mica for electrical purposes.

In the year 1902 (Report Insp. of Mines, Calcutta, 1902)

*Mineral Industry, 1899, page 428.

there were employed in mica mining 9,500 persons, while the production and sales in the same year were 1,685 tons, valued at \$507,770. This output is supposed to come from over 200 mines, which means a production of only eight tons per mine. From this fact it is evident that individual mining operations are not conducted on a large scale. Most of the mica deposits are of a pockety nature. As a whole, their occurrence is very irregular and taking also the shortness of the dry season into consideration it is clear that mining resembles a perpetual shifting of operations from one place to another. However, in spite of all these drawbacks the cheapness of labour and the richness of the individual deposits makes mining profitable.

Mica mining in India has its history. We know that the Hindoos have been mining mica for centuries. The mines near Patna and Delhi are the oldest in the country. Dr. P. Breton visited these mines in 1826 and found as many as 5,000 natives working in them. In 1849 Dr. McClelland records an output of 800,000 pounds. The first exports of mica were made from Bengal in 1863 and amounted to about 7,500 pounds. From this time the exports have steadily increased, but it was not until the adoption of mica for electrical purposes that the mining assumed large proportions.

The productive mica areas of India are practically restricted to the two districts of Gaya and Hazaribagh, in the Bengal presidency, and Nellore and Nilgiti of the Madras presidency.

According to A. Mervyn Smith* the mines in Bengal (Fig. 35) are situated between 85° to $86^{\circ} 30'$ east longitude and $24^{\circ} 25'$ north latitude. They are distributed over a large series of parallel ranges of low hills, some 400 feet above the surrounding country and about 1,200 feet above sea level. They form the boundary between the Hazaribagh district on the south and the Gaya and Monghyr districts on the north, being part of the Bengal presidency. The direction of these ranges is east and west. The mines at present of most importance are situated in the districts of Hazaribagh and Gaya in Behar. The mineral is also found in certain parts of Manbhoom and Singchoom (Chota Nagpur), but all attempts to work these mines to advantage have failed. The principal mines in the Hazaribagh district are Dumko Gharanchi, Bochagta, Salboya and Kadama. Most of these mines are situated

*Institution of Mining and Metallurgy, 1898, p. 168.

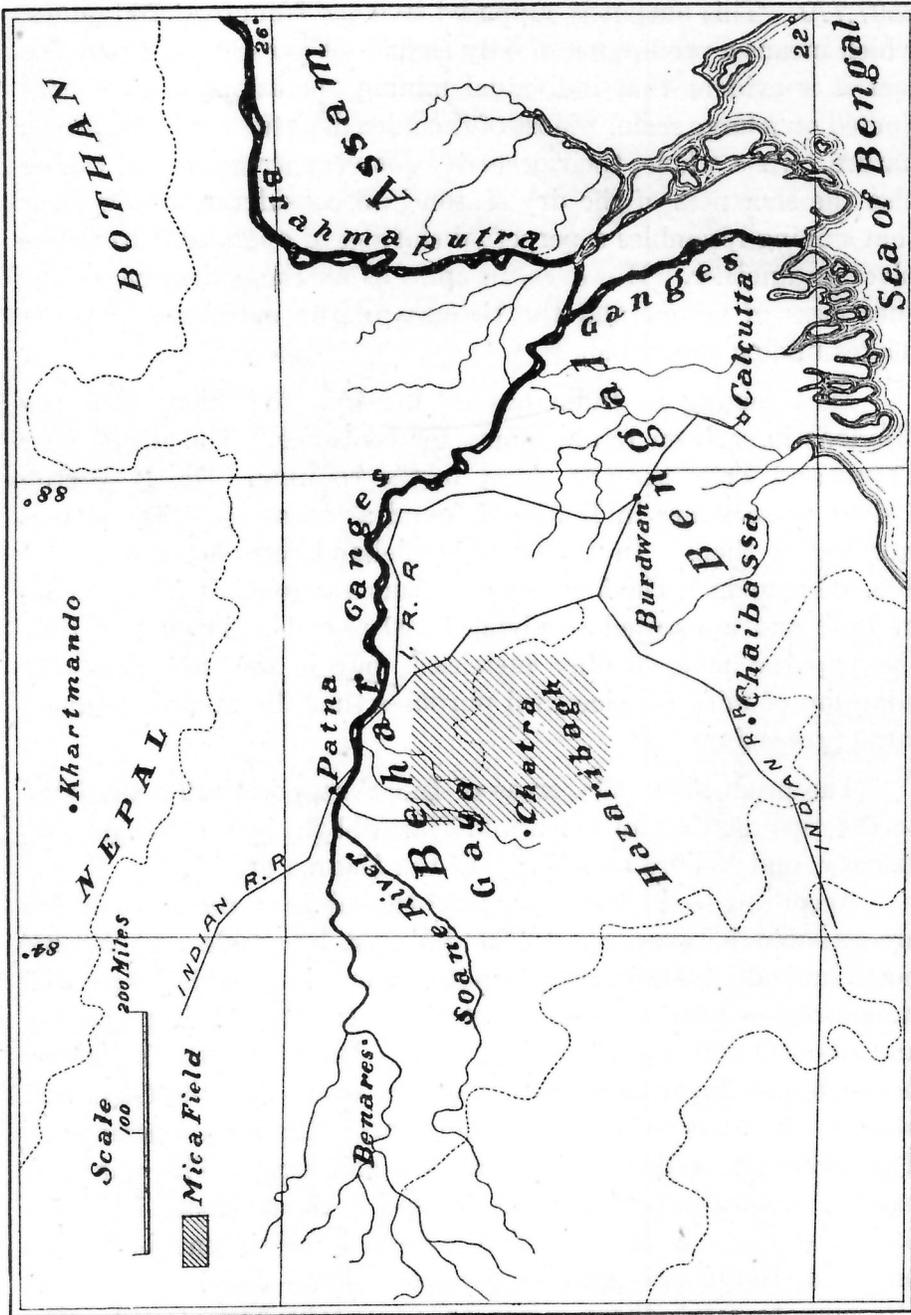

FIG. 35.—The Mica Fields in Bengal, India.

in the Koderma Government estate, both inside and outside the Government reserve forests, the rest being scattered through other parts in the vicinity of that country. In the Hazaribagh district there were employed in 1902 6,254 persons in 61 mines, producing 768 tons of mica, 628 tons being mined by one company.

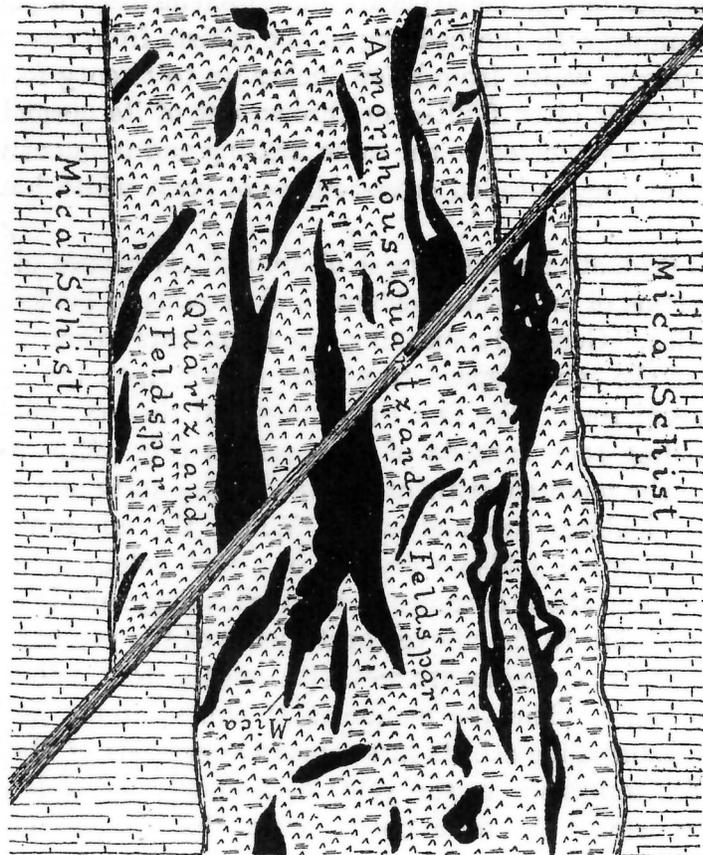

FIG. 36.—Section of Pegmatite dike, Hazaribagh, India.

Upside down

Large tracts of gneiss grading into mica schist occur throughout the Bengal mica area. In immediate contact with the mica deposits tourmaline schists, hornblende rocks and quartzites with intrusive dikes of a fine grained diorite are also found. The hornblende rocks resemble the diorite and it is not uncommon to find a mica deposit between these two rocks. The mica met with in the schists is of the muscovite variety, while black mica (biotite) and a red mica (lepidolite) are also found. The mica schists are

highly schistose, breaking up into thin laminæ, and consist principally of small mica sheets cemented together with an admixture of feldspar and quartz. The gneisses are classed in Indian geology as among the younger members of the Archæan formation. They have nearly an east and west strike and dip to the north at an angle of about 75° .

The mica of commerce occurs almost exclusively in pegmatite veins, running with the bedding of the schists from east to west and varying in width from a few inches up to twenty feet. The country rock is often faulted or thrown out of its normal strike. The veins are subjected to the same faulting and frequently at the point of faulting so-called cross-courses of great width have been formed.

The pegmatite veins consist of amorphous masses of quartz, large crystals of orthoclase feldspar and crystals or books of muscovite mica. Generally speaking, their contents in mica and the quality of the same depend to a large degree upon the nature of the adjacent rock. We find the richest and the best mica where the including rock consists of mica schists (Fig. 36). Near the quartzite the main constituent of the vein is quartz and but little mica and feldspar are met with. Where the adjacent rock is highly feldspathic, feldspar crystals of a pink colour predominate in the lode and the occurrence of mica is insignificant. (Fig. 37).

In addition to the above constituents of the pegmatite veins many accessory minerals are met with, such as tourmaline, garnet and columbite. The tourmaline is at times largely developed; near the tourmaline schists large, massive crystals of black tourmaline are numerous in the vein; occasionally, crystals of tourmaline penetrate the mica books across the laminæ and render them unfit for use.

The native mines are of the most original and primitive character. No system of any kind is followed and the deposits are exploited in the simplest way. There is no machinery worth mentioning. Open cuts along the outcrops of the veins, where mica crystals are found, alternate with crosscuts at right angles through the vein formation. These cuts have a depth of from twenty to fifty feet. The sides, on account of the decomposed nature of the veins near the surface, are very dangerous, no timber of any kind being used, accidents are very frequent and the miners are often buried beneath the fallen walls. In an exceptionally rich deposit, where the decomposition of the vein continues in depth,

the work of exploitation differs somewhat from the above; the vein is followed to a greater depth, sometimes to 200 feet, by inclines in a zigzag form. Long rows of native women are placed on these inclines for the lifting of the mica to the surface or for draining the pits. These women are placed near one another in two rows from the water level to the surface. They pass from hand to hand baskets filled with mica or pitchers filled with water. The full receptacles are handed up one line and the empties pass down the other. As many as seventy women are sometimes placed in these zigzag inclines.

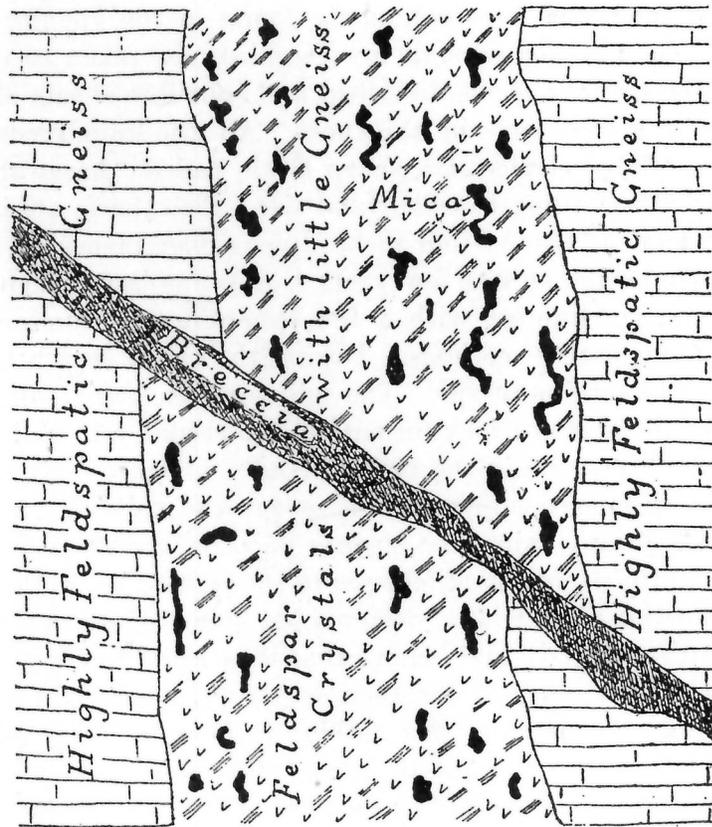

FIG. 37.—Mica Vein in Gneiss, Hazaribagh, India.

In order to ventilate the inclines and draw out the mica waste material, perpendicular, circular shafts two feet in diameter are put down. Sometimes as many as thirty of these circular shafts can be counted along the strike of the vein and within a few feet from each other.

Work is conducted only in the dry months from November to May. The miners are a local tribe called the "Bandathis"; men, women and children work in the mine when they have no agricultural work in the field. Work generally begins at dawn and ends at dusk. No explosives of any kind are used, but where the vein is hard but rich enough to pay for the labour and fuel large fires are kindled against the face of the lode and when the walls are sufficiently heated water is thrown on it. This sudden cooling causes the rock to shrink and crack. Wedges of soft iron are then driven into these cracks and in this way large boulders are detached. These tools are manufactured in a primitive way from the magnetite ores commonly found in the vicinity of the mines. The exposed crystals are chiselled out, taken to the surface in the manner above described and split into sheets of about one-eighth of an inch in thickness. All the rough edges are trimmed off by means of a sharp sickle called "hasawah" and then sorted according to colour and size. The sheets are in some cases as large as twenty-four inches by eighteen inches.

Although in the last few years Europeans have taken up the mica industry, mining, with a few exceptions, is conducted on these purely native methods. During the rains, search is made for likely looking outcrops. The mica schists, being softer than the other members of rock formation, are eroded into valleys, the quartzose beds making the ridges of hills, and a certain amount of humus from the adjacent hills covers the valleys. After exceptionally heavy rains, the surface deposits are washed off and with them the decomposed feldspar of the pegmatite veins, leaving exposed tufts of partially decomposed mica. The natives call these tufts "foo-foo" and believe that they grow during the rains, as they cannot account for their exposure at the surface after heavy rains, where there was nothing to be seen before the rain. Having discovered several of these "foo-foo" spots, these are marked for mining operations as soon as the dry season begins. Parties made up of men, women and children are set to work on these outcrops and the books of mica dug out, packed in loads of about thirty pounds and brought in at dusk to the central store. Here skilled workmen are trimming the mica from the different diggings and mines. Before each man is a stout peg, driven firmly into the ground and protruding about eighteen inches. The mica crystals are split by means of sharp sickles into plates of one-eighth of an inch in thickness, the point of the knife being used for opening

these sheets. Imperfect laminae are peeled off the plates till both surfaces show a clean, even face. The plate is drawn against the side of a peg and the sickle drawn downwards to trim off the jagged ends and irregularities along the edge of the mica sheets. After trimming, the plates are sorted for the market, England and the United States being the chief buyers.

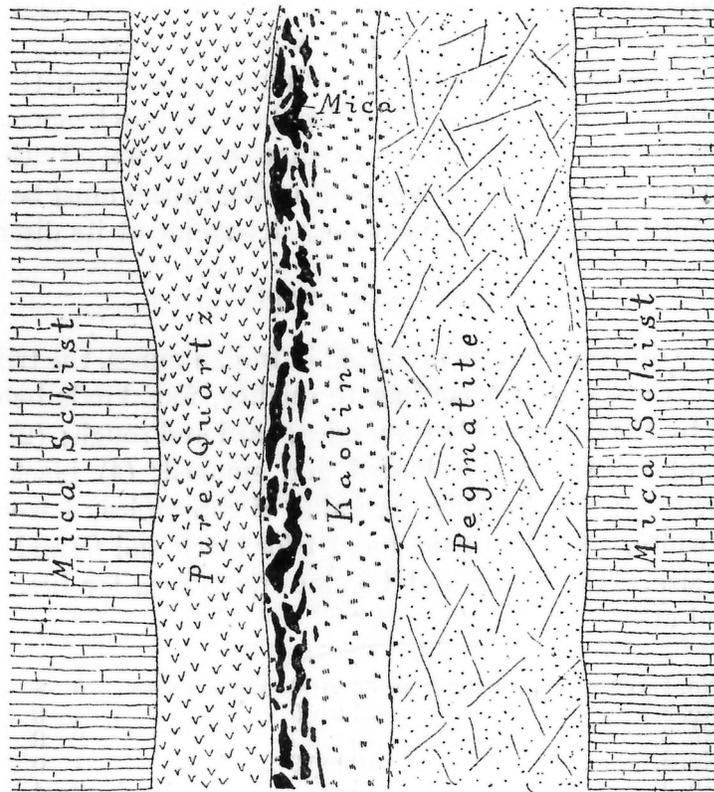

FIG. 38.—Pegmatite Vein in South-East Wainad, Nilgris, Madras Presidency, India.

As to the Nellore district, Mr. Thomas Holland of the Geological Survey of India describes the pegmatite as being found in the low lying plain mostly concealed by recent formation and alluvium and consequently their full extent will never be known.

The mica occurs here also in pegmatite dikes cutting the mica schists. These dikes are sometimes highly decomposed, the main or centre part being kaolin, while the balance of the dike is made up of pure feldspar or quartzose rock. The mica is deposited between this rock and the kaolin (Fig. 38).

Mining, on account of the flat surface, is generally more expensive than that practised in the high ground of the Bengal mica belt. There were in 1902 sixty-nine mines in operation, employing 2,965 persons and producing 228 tons of mica. The Government leases land at a fixed rate of fifty rupees per acre, while private lands are leased by arrangement. In the beginning of 1902 the Madras Board of Revenue amended the law for mica mining in the Nellore district to conform to the general mining rules of the Government of India. This action was made necessary by the fact that speculators had obtained mining leases which they had no intention of working and which they held for purely speculative purposes to the detriment of genuine operators. With each application for mining leases a deposit of 500 rupees must be made, or such sums as the Government may determine at its discretion.

PRICES AND GRADES.

Of the different grades produced in Indian mines, the trimmed mica sheets are sorted according to quality, four kinds being recognized by the dealers: (1) ruby mica, hard and rough; (2) white transparent mica; (3) discoloured and smoked; (4) black mica and flawed. If 8 represents the value of ruby mica, 4 would be paid for white, 2 for discoloured and 1 for black and flawed sheets of equal size. The sizing and London quotations for best Ruby per pound are:—

			s.	d.
No. 1,	Sheets measuring from 36 to 50 square inches	..	6	8
No. 2,	“ “ 24 to 36 “	..	4	0
No. 3,	“ “ 16 to 24 “	..	2	0
No. 4,	“ “ 10 to 16 “	..	1	0
No. 5,	“ “ 6 to 10 “	..	0	4
No. 6,	“ “ 4 to 6 “	..	0	2

These sheets are trimmed into the best shape that will clear them of flaws. Square, rectangular, or diamond shaped sheets fetch higher prices. The sheets are packed into boxes of 100 lbs. and carted to the railway station for transport to the nearest port. The distance of the mines from the railway varies between thirty and 140 miles.

As to the quantity of mica available in India, there is no doubt that the pegmatite veins are numerous and, compared with those of other countries, large, while the quantity of mica in some places is abundant. But the method of working these mines is wasteful in the extreme and fully 90% of the mica mined is injured

and rendered unfit for use. Whatever truth there may be in the statements regarding the richness of the deposits, there appears to be no question that, before long, modern methods of mining must be adopted, in order to make mining more profitable.

Wages are very low, women get threepence a day, while good natives work for fourpence. A first class native foreman—and only such can be employed under the circumstances—receives from eightpence to tenpence a day. On account of the absence of any machinery, it is difficult to follow the deposits beyond 100 feet in depth; many a mine still showing immensely rich mica deposits has been abandoned. There cannot be the slightest doubt that, with the introduction of modern mining methods, the waste of mica will be much less, a better quality will be secured and the life of the mines will be prolonged until the complete exhaustion of the deposits. At present, only the decomposed or partially decomposed parts of a vein are mined and it is evident that the mica must have simultaneously undergone a certain partial decomposition. Mining in depth in the hard vein material would yield hard, not decomposed mica, and in this way would increase the efficiency of the mine, both as to quality and quantity.

Some interesting mineralogical features are often observed in the Indian mica. The sheets are at times queerly marked: In places one-half of each sheet will be muscovite and the other half biotite, the line of division between the two colours being perfectly straight while there is no other apparent change in the uniformity of the sheet. Other plates, again, are chequered in black lines, the lines being due to magnetite. In some cases dendritic inclusions of quartz between the laminae may be found. Of course, all these defects have an influence upon the price. The most valued colours are pure ruby, amber, light green and transparent white. There is also a silver white, which the natives prize for ornamental inlaid work.

COMPARISON OF INDIAN AND CANADIAN MINING METHODS.

As mentioned above, the mining methods in India are of a very primitive character and wasteful in the extreme. Most of the exploitations are only superficial and, as a rule, only the best deposits have been worked. The native method, of course, does not require any large capital, it gives quick returns for a small outlay, but when a certain depth, say about thirty feet is reached, the working of the mine drags along from day to day until such

methods fail to produce any more mica, though more may be in sight. The life of such a mine is a little longer than the exploratory stage of a mine in Canada. The mica miner of India has not been educated to realize that the occurrences, though widely distributed and in some places rich, are limited in extent and that the present methods of extreme wastefulness must cease if India is to successfully compete with other countries.

Since 1902 the "Indian Mica Company" which is operating near Bendi, Hazaribagh, has commenced to discard the original mining methods entirely and is opening up a pegmatite vein by systematic development work. Three inclined shafts have been sunk on the vein, while over 3,000 feet of drifts and crosscuts have exposed the nature and character of the deposits. Modern hoisting machinery is employed, while drainage of the mine is effected by a Cameron pump. Common gunpowder is used and is preferable to dynamite, as it is cheaper and sufficiently effective in that class of rock. This mine was formerly worked by natives, who mined only the foot wall, the much richer deposits, now proved by crosscuts to occur near the hanging wall, were passed unnoticed.

World's Production of Mica.

In the following table the world's production is given for the year 1902, (the figures for 1903 have not yet been completed).

	Value.	Persons Employed.
India	\$507,770	9,214
Canada	242,310	715
United States.....	98,859	300
Brazil and other countries.....	55,200	250
	\$904,139	10,479

APPENDIX.

**ABSTRACT FROM THE MINING LAW OF THE PROVINCE
OF QUEBEC.**

SEC. 5.—MINING CONCESSIONS, THEIR FORM AND
DIMENSIONS.

1436. Mining concessions are divided into three classes and each of them respectively, in addition to the usual allowance of five per cent, for highways, in each case, shall be of the following form and dimensions, viz:—

1. In unsurveyed territory:—

The first class contains 400 acres:—52 chains in width, by 80 chains and 80 links in depth;

The second class contains 200 acres:—26 chains in width, by 80 chains and 80 links in depth;

The third class contains 100 acres:—13 chains in width, by 80 chains and 80 links in depth.

2. In surveyed townships:—

The three aforesaid classes respectively comprise: one, two and four lots, as regularly divided, or more or less, as the case may be, if such lots, being of irregular form, contain more or less than one hundred acres each, in superficies.

1439. All mining concessions, comprised in an unsurveyed territory, shall be surveyed by a provincial land surveyor, acting under the instructions of the Department of Crown Lands, and be connected with some known point in previous surveys, so as to be laid down upon the office maps of such territory, of record in the Department.

Such surveys are made at the cost of the applicants, who are required to furnish with their application to purchase the plan of surveyor establishing the position and dimensions of the concessions they desire to purchase, with the field-notes and *procès-verbaux* of the operations; the whole in conformity with the present law and to the satisfaction of the Commissioner.

SEC. 6.—ACQUISITION OF MINING LANDS.—DUTIES OF PROPRIETORS WHO SELL THEIR RIGHTS.

1440. All lands, supposed to contain mines or ores, belonging to the Crown, may be acquired from the Commissioner of Crown Lands:—

1. As a mining concession by purchase, or
2. Be occupied and worked under a mining license.

1441. The mining rights belonging to the Crown in the lands of private individuals may also be acquired in the manner indicated in the foregoing article.

1442. Every owner of mining land is bound, whenever he sells, transfers or alienates his rights in such land, to give notice thereof to the Commissioner within thirty days of such sale, transfer or alienation.

SEC. 7.—PRICE OF MINING CONCESSIONS.—RESERVES OF THE RIGHT OF CUTTING TIMBER THEREON.

PRICE OF MINING CONCESSIONS.

1443. When it concerns superior* metals, no sales of mining concessions, containing more than four hundred acres in superficies, shall be made to the same person. The Lieutenant-Governor in Council has, nevertheless, the right to grant to any person, upon sufficient proof of his capital and resources, a larger extent of territory, but not to exceed one thousand acres.

When it concerns inferior* metals, it shall be lawful for the Lieutenant-Governor in Council to determine for each mineral the extent of the mining concession which may be granted to the same person.

1444. With such applications to purchase and the production of the documents mentioned in this law, applicants are required to pay to the Department of Crown Lands the entire price of the mining concessions which they desire to purchase at the following rates:—

1. If for the mining of superior metals on lands situated more

*The words "superior metals" include the ores of gold, silver, lead, copper, nickel, and also graphite, asbestos, mica and phosphate of lime; and the words "inferior metals" mean and include all the minerals and ores which are not included in the preceding definition and which are of appreciable value.

than twelve miles from a railway in operation, five dollars an acre, and if on lands situated less than twelve miles from such railway, ten dollars an acre;

2. If for the mining of inferior metals, the price shall be fixed by the Lieutenant-Governor in Council.

1446. Unless stipulated to the contrary in the letters-patent:

1. In concessions for the mining of superior metals, the sale of such concession shall give to the purchaser the right to mine for all metals which may be found therein;

2. In concessions for the mining of inferior metals, the sale of such concession shall give to the purchaser the right to mine for inferior metals only.

RESERVE OF RIGHT OF CUTTING TIMBER ON MINING CONCESSIONS.

1448. The holders of licenses to cut timber have, under such license, the privilege of cutting on all mining concessions granted within their limits pine timber measuring twelve or more inches in diameter on the stump, and spruce timber measuring nine or more inches in diameter on the stump.

This privilege shall, however, finally expire after a period of three years from the date of the issue of the deed of sale.

1449. The letters-patent for Crown land, sold as mining concessions, within the meaning of this law, shall contain a clause reserving all trees of pine or spruce timber in favor of the Crown; and, subject to the provisions of the preceding article, the Commissioner may grant to any person whomsoever the right of entering upon the said lands and cutting and taking therefrom, according to the regulations, the trees so reserved and making and keeping in repair across the said mining concessions all roads necessary for such operations.

1450. The purchasers or proprietors of such mining concessions have, in the case of the two preceding articles, the right to cut and take away for their own use such trees as they may require for the construction of the buildings and dependencies necessary for their operations.

SEC. 8.—CANCELLING OF SALES OF MINING LANDS.

1451. Mining lands shall be sold on the express condition that the purchaser shall commence *bona fide* the mining of the minerals therein contained within two years from the date of purchase and

that during such delay the purchaser shall in such working spend a sum of not less than five hundred dollars, if for superior metals, and of not less than two hundred dollars, if for inferior metals.

The Commissioner may cancel the sale of such mining land in default of the performance of the conditions herein mentioned, according to the mode followed for the cancellation of sales of public lands.

Letters-patent shall be issued only on satisfactory proof that the foregoing conditions have been fulfilled.

SEC. 9.—LICENSESES.

EXPLORATION AND PROSPECTING LICENSES.

1452. Any person, firm or company may, without a license, prospect and search for mines or ores upon public lands not already occupied as mining concessions or otherwise.

When any such person, firm or company may desire to enjoy the benefit of such license he shall obtain from the Commissioner such license for such purpose on conforming to the provisions of the following article:—

1453. The application for an exploration and prospecting license shall contain as exact a description as possible of the land required, to the satisfaction of the Commissioner, and shall be accompanied by the following fees, as the case may be:—

1. If the mine is upon private lands, two dollars for every hundred acres; every less number of acres to count as one hundred;

2. If the mine is upon Crown lands,—

a. In surveyed territory, five dollars for every hundred acres; every less number of acres to count as one hundred;

b. In unsurveyed territory, five dollars for each square mile.

Such license is valid for three months and may be renewed.

1455. Whoever, under such license, searches and prospects as aforesaid shall make a report to the Commissioner, or to the inspector of the result of his operations.

1456. The holders of such license may afterwards purchase such mine by paying the prices mentioned in article 1444 and by conforming to the present law and also to the regulations passed in virtue thereof.

FORM OF MINING LICENSES.

1460. There are two descriptions of licenses for mining known as follows, to wit:—

1. Private lands' license, where the mining rights belong to the Crown.
2. Public lands' license.

GRANTING AND DURATION OF LICENSES.

1461. Mining licenses are granted on payment of a fee of five dollars and of an annual rental of one dollar per acre.

2. Every such license is valid for one year from the date of issue and is transferable only with the consent of the Commissioner.

3. It cannot be granted for an extent of over two hundred acres in superficies, unless the Lieutenant-Governor in Council otherwise decides.

4. The licensee may, before the expiry of his license, and not later than ten clear days thereafter, renew such license on payment of a like fee of five dollars or of any such other sum as may be determined by law at the time of its issue and of an annual rental of one dollar per acre.

5. No such mining license can be renewed except upon payment of the said fee and of the said annual rental.

POWERS OF LICENSEES ON PRIVATE LANDS.

1465. The holder of a mining license or the owner of mining rights on private lands is authorized to work the mines thereon with the consent of the private person, or on his refusal by compelling him thereto in the manner provided by the following articles.

ARBITRATION FOR MINING ON PRIVATE LANDS.

1466. Every holder of a mining license or every owner of mining rights on private lands or their representatives who wish to mine on the land of such private person must first cause to be served a notice in writing stating:—

1. That they intend to mine on the land of such private person;
2. That they are ready to pay the damages arising from such mining operations to be assessed by mutual agreement.

1467. The notice shall give a delay of one month from the date of the service to the said private person to answer and make such agreement if present, and, if absent from the Province, double delay, and in the latter case the notice shall be inserted in French and English three times in a newspaper of the district, if there is such newspaper, if not, in a newspaper of an adjoining district.

MISCELLANEOUS PROVISIONS RESPECTING APPLICANTS FOR AND HOLDERS OF LICENSES AND PERSONS WORKING MINES.

1491. Every applicant for a license to mine upon public lands has a right to plant a wooden picket at each corner of the lot for which he desires to obtain such license.

1492. Every such applicant, after having staked out the location of his land in the manner determined in the preceding article, is bound to give written notice thereof without delay to the mining inspector.

1493. Such notice shall give the name of the applicant, indicate the place where the land is situated, contain a complete designation and description of the land and mention where such applicant erects his domicile, under penalties.

1494. The discoverer of a new mine on public lands is entitled to a free mining license, valid for twelve months, for the area allowed by article 1461, or by any regulations which may be issued under it and in force when such discovery is made; provided that such discovery has been immediately reported in writing to the inspector of the mining division.

1495. Any one who does not immediately report such discovery shall be deprived for the space of one year of the right to mine on public lands.

1496. No person is considered to be the discoverer of a new mine, unless the place of the alleged discovery is in a region unknown as a mining region, or at least a distance of thirty miles from the nearest mine.

1497. Every person holding a mining license, upon renewing the same, is bound, under penalty of the refusal of such renewal, to make to the inspector of the mining division, in addition to the annual statement which he is bound to furnish in virtue of the following article, a full and true statement, under oath, of the work performed and of the minerals obtained by him during the

term of such license, which statement may be entered upon the expiring license.

1498. Every owner of mining rights, whether he mines himself or by others, and every person working mines must, during the first ten days of the month of January in each year, furnish a sworn statement of his operations for the past year, indicating the quantity of mineral extracted, its value at the mine and the number of workmen employed, as well as a list of the names of persons killed or injured in working the mines.

1499. No title to a mining concession or license shall, without the formal consent of the proprietor of the soil, give a right to mine or to open pits of galleries, or to erect machines or stores in fields, yards or gardens, or upon lands close to dwelling houses, or boundary fences or dwellings, nor even to enter such yards or habitations.

1500. Every person who prospects or mines for minerals upon lands adjoining a mining division is subject to the provisions of this law, as if he worked within the limits of such mining division.

SEC. 10.—SPECIAL PROVISIONS RESPECTING MINING.

WATER-COURSES AND EXCAVATIONS.

1509. Every miner who makes a pit, shaft or any excavation whatever to a depth of four feet and over is bound to enclose the same with a fence at least four feet in height, if he discontinues working the same for a period of eight days.

1510. All owners of claims and mining locations, bounded by water-courses or rivers upon public as well as upon private lands, may make use of such water-courses or rivers in working their respective claims or locations, but without hindering each other.

1511. Every dispute arising between the parties on the subject is settled and decided by the inspector of the mining division and whosoever disobeys the order of the inspector is liable to penalties.

**ABSTRACT FROM THE MINES ACT OF THE PROVINCE
OF ONTARIO.****MINERALS ON CROWN LANDS.**

8. Any person or persons may explore for mines or minerals on any Crown Lands, surveyed or unsurveyed, and not for the time being marked or staked out and occupied as hereinafter mentioned, except on such lands as may by the Lieutenant-Governor in Council have been withdrawn from sale, location or exploration as being valuable for their pine timber or for any other reason, and any person attempting to explore, occupy or work any lands so withdrawn shall incur a penalty of \$20 and costs, and in default of payment of the fine and costs such persons may be imprisoned for any period not exceeding one month.

9. (1) Crown lands not situated within any mining division which are supposed to contain ores or minerals, and mining rights in lands, the ores or minerals whereof have been reserved by the Crown, may be sold or located as mining lands in blocks, sections or lots, to be called "mining locations."

(2) Where such Crown lands are situated within a mining division they may be occupied and worked as "mining claims," under miner's licenses, as hereinafter provided.

LICENSE FEES.

10. No owner of any mine shall carry on the business of mining for any ore or mineral in respect of which a license fee is imposed, without first taking out a license under the provisions of this Act.

11. (1) The licenses shall be signed and issued by the Commissioner of Crown Lands or the Director of the Bureau of Mines in such form as the Lieutenant-Governor in Council may direct and shall be dated as of the 1st day of May in each year and shall continue in force until and including the 30th day of April of the next ensuing year and no longer.

(2) Every license issued under this Act shall designate the property in respect of which it has force and when the property belongs to two or more persons the license may be issued in the name of any one or more of them and when the property belongs to a corporation the license may be issued in the name of the corporation.

EXPLORATORY DRILLING.

22. (1) The Commissioner of Crown Lands may, out of the moneys voted for that purpose, purchase not more than two diamond drills to be used in exploratory drilling of ores or minerals in the Province, under rules and regulations to be made by the Lieutenant-Governor in Council.

(2) The regulations shall, amongst other things, provide:—

- (a) For the control and working of the drills under the direction of a person or persons employed for the purpose by the Bureau of Mines.
- (b) As to the payment of freight charges where the drills are used upon mines or lands other than those owned by the Crown.
- (c) As to the application for the use of the drills and the method of dealing therewith.
- (d) As to the charges for the use of the drills and for damages thereto or wear and tear connected therewith, and otherwise as to the Lieutenant-Governor in Council shall seem meet.

BUREAU OF MINES AND OFFICERS.

23. There shall be established in connection with the Department of Crown Lands a Bureau of Mines to aid in promoting the mining interests of the Province and the Lieutenant-Governor in Council may appoint an officer to be known as Director of the Bureau of Mines who shall act under the direction of the Commissioner of Crown Lands, unless and till otherwise ordered, and who shall be paid such salary as shall be voted by the Legislature.

FORM, SIZE AND PRICE OF LOCATIONS.

41. The price per acre of all Crown lands to be sold as mining lands or locations shall be:—

- (a) If in surveyed territory within six miles of any railway\$3.50
- (b) If in surveyed territory within twelve miles of any railway..... 3.00
- (c) If situated elsewhere in surveyed territory. 2.50
- (d) If in unsurveyed territory and within six miles of any railway 3.00
- (e) If in unsurveyed territory within twelve miles of any railway..... 2.50
- (f) If situate elsewhere in unsurveyed territory..... 2.00

The price per acre for a patent of mining rights shall be one-half of the above rates.

42. A prospector or explorer who is the first discoverer of valuable metals, ores or minerals shall be entitled to a free grant of one location of 40 acres where the vein, lode or other deposit is not less than five miles from the nearest known mine, vein, lode or deposit of the same metal, ore or mineral respectively, and proofs of his being the first discoverer and of the distance from the nearest known occurrence of the same metal, ore or mineral shall be made by affidavit to the satisfaction of the Commissioner of Crown Lands.

CONDITIONS ON WHICH LOCATIONS TO BE HELD.

44. (1) The grantee or owner of any mining location sold and patented under sections 41 and 42 shall, during the seven years immediately following the issue of the patent therefor, expend in stripping or in opening up mines, in sinking shafts, or in other actual mining operations, exclusive of all houses, roads and other like improvements, a sum not less than at the rate of \$1 per acre during the first two years and a sum not less than at the rate of \$1 per acre during each remaining year of the said seven years, or its equivalent in less time, and the said expenditure may consist of labor actually performed by grown men to be computed at the rate of \$2 per man per day; but if two or more locations are contiguous, the whole of the mining work herein required may be done upon one of them.

(2) In default of such expenditure during the first two years or during any subsequent year of the said period of seven years all rights connected with any such mining location shall upon an Order in that behalf being made by the Lieutenant-Governor in Council, upon the report of the Director of the Bureau of Mines that such expenditure has not been made, revert to and be vested in His Majesty, his successors and assigns, for the public uses of the Province, freed and discharged of any interest or claim of any other person or persons whatsoever.

(3) It shall be the duty of the grantee, owner or holder of a mining location to make a report of the performance of the mining operations herein required according to a form which may be obtained on application to the Director of the Bureau of Mines, and such report duly verified by affidavit shall be completed and forwarded to the Director of the Bureau within thirty days after

the end of the year or term of years, as the case may be, for which the expenditure is required.

45. (1) Instead of granting any mining lands in fee simple the same may be leased or demised for a term of ten years and unless otherwise provided by regulation the rental for the first year shall be \$1 per acre and for each year of the term thereafter it shall be per acre:—

(a) If in surveyed territory within six miles of a railway	30c.
(b) If in a surveyed township within twelve miles of a railway.....	25c.
(c) If situate elsewhere in surveyed territory.	20c.
(d) If in unsurveyed territory within six miles of a railway.....	25c.
(e) If in unsurveyed territory within twelve miles of a railway	20c.
(f) If situate elsewhere in unsurveyed territory.	15c.

The rental of mining rights when leased shall be one-half of the above rates.

(2) Every such lease shall be subject to such covenants and conditions on the part of the lessee, his executors, administrators and assigns, to be paid, observed and performed, as shall be provided by regulation.

(3) The said lease may among other things provide for the removal, in case of forfeiture or non-renewal of the lease of any mining plant and machinery which the lessee, his executors, heirs and administrators shall have placed or erected upon the said premises.

(4) There shall be expended in stripping or in opening up mines or in sinking shafts, or in other actual mining operations the like sums upon lands leased under the provisions of this Act as is provided by section 44 shall be expended in the case of sales or grants and within the like periods and in default of such expenditure the lease shall be forfeited and become absolutely void, and the said lands, mines and minerals shall, upon an Order on that behalf being made by the Lieutenant-Governor in Council upon the report of the Director of the Bureau of Mines that such expenditure has not been made, revert to and become the property of and be vested in His Majesty, his successors and assigns, and shall cease to be the property of any other person or persons whatsoever.

(7) At the expiration of the said term of ten years for which a mining location has been leased, if the yearly rental has been paid and if all the covenants and conditions of the lease have been fulfilled, the lessee shall be entitled to receive a patent for the location; or he may at any time during the demised term, upon payment of rent for the full period of the term and performance and fulfilment of all other covenants and conditions of the lease, obtain a patent for the location; and the provisions of this subsection may apply to any mining locations heretofore leased under the terms of The Mines Act.

RESERVATION OF TIMBER.

50. (1) The patent for all Crown lands sold or granted as mining lands shall contain a reservation of all pine trees standing or being on the lands, which pine trees shall continue to be the property of His Majesty, and any person holding a license to cut timber or sawlogs on such lands may at all times during the continuance of the license enter upon the lands and cut and remove such trees and make all necessary roads for that purpose.

(2) The patentees or those claiming under them (except patentees of mining rights hereinafter mentioned) may cut and use such trees as may be necessary for the purpose of building, fencing and fuel on the land so patented, or for any other purpose essential to the working of the mines thereon, and may also cut and dispose of all trees required to be removed in actually clearing the land for cultivation.

(3) No pine trees except for the said necessary building, fencing and fuel, or other purposes essential to the working of the mine, shall be cut beyond the limit of such actual clearing; and all pine trees so cut and disposed of, except for the said necessary building, fencing and fuel, or other purposes aforesaid, shall be subject to the payment of the same dues as are at the time payable by the holders of licenses to cut timber or sawlogs.

51. The preceding section shall apply to all leases issued under this Act, other than leases of mining rights hereinafter mentioned, with the following limitations and variations, that is to say:—

1. No pine trees shall be used for fuel other than dry pine trees and (except for domestic and household purposes) only after the sanction of the timber licensee or the Department of Crown Lands is obtained.

2. In case it is intended to clear for cultivation any portion of the lands so leased it shall be the duty of the lessee to give the holder of the timber license three months' notice in writing of his intention to clear, and the area intended to be cleared, and its position, so that such timber licensee may remove any timber on the area intended to be cleared.

3. If at the expiry of the time limited by the notice such timber shall not have been removed from the area intended to be cleared, then the lessee shall be at liberty to cut and dispose of all trees required to be removed in actually clearing for cultivation the area specified in such notice, and all trees so cut and disposed of shall be subject to the payment of the same dues as are at the time payable by the holders of the licenses.

4. If during the first ten years it is sought to cut timber, other than pine, on the lands so leased, beyond what is required for building, fencing, or fuel, or in the course of actual clearing for cultivation, or for any other purpose essential to the working of the mines as hereinbefore provided, application shall first be made to the Commissioner of Crown Lands, who may grant authority to cut such timber and fix the rate of dues to be paid thereon.

SURFACE RIGHTS AND MINING RIGHTS.

52. The ores, minerals and mining rights that have in the patents been reserved to the Crown in any land may be granted or leased to the owner of the surface rights who applies therefor, unless a patent or mining lease has been previously applied for by a person who is the first discoverer of valuable ore or mineral in or upon the premises, when such applicant shall have priority.

53. (1) Where the surface rights have been granted, leased or located, and a patent or lease of mining rights shall thereafter be granted in respect of the same land, in the event of the parties failing to agree upon compensation for injury or damage to the surface rights either in the form of a specified interest in the mineral rights or ore or mineral, to be secured to the owner of the surface rights, or by payment or agreement to pay in money, or the giving of security, the Director of the Bureau of Mines shall order and prescribe the manner in which compensation for the damage or injury to the surface and surface rights shall be ascertained, paid or secured.

(2) For the purposes aforesaid the said Director is empowered to appoint a valuator or valuers, arbitrator or arbitrators, who

shall have all the powers for the purposes for which he or they shall be appointed of an arbitrator or arbitrators under any Act of the Legislature, or he may direct that such compensation shall be ascertained by suit or action in any County or District Court.

54. No person shall have the right of entry as prospector or explorer upon the surface rights of that portion of any lot used as a garden, orchard, vineyard, nursery, plantation or pleasure ground, or upon which crops that may be damaged by such entry are growing, or on which is situated any spring, artificial reservoir, dam or waterworks, or any dwelling-house, out-house, manufactory, public building, church or cemetery, unless with the written consent of the owner, lessee or locatee, or of the person in whom the legal estate therein is vested.

MINER'S LICENSE.

56. (1) On payment of a fee of \$10, or such other sum as may be fixed by regulation, the Director of the Bureau of Mines (or the inspector of a division when so authorized by the Commissioner of Crown Lands) may grant to any person, registered partnership, or mining company incorporated under the laws of the Province applying therefor a license to be called a "miner's license," which shall be in force for one year from the date thereof and shall not be transferable except with the consent of the Director of the Bureau or the Inspector of the division.

(2) The person, partnership or company named in a license shall be called the "licensee," and upon payment of the fee fixed by law or regulation such licensee shall have the right to renewal if application is made therefor before the expiration of the license or within ten days thereafter.

57. A miner's license shall authorize the licensee to explore any portion of the mining division named in his license, and to mine during one year from the date of the license and from the date of any renewal thereof, on any mining claim marked or staked out by such licensee on Crown lands, as hereinafter provided; but any person may be employed by the licensee to assist him in working such claim, or the licensee may organize a company to work the same.

STAKING OUT AND HOLDING MINING CLAIMS.

58. A licensee who discovers a vein, lode or other deposit of ore or mineral in place within the division mentioned in his license shall have the right to mark or stake out thereon a mining

claim, providing that it is on Crown lands not withdrawn from location or exploration and is not included in a claim occupied by another licensee, or on lands the mines, minerals and mining rights whereof have been reserved by the Crown, and shall have the right to work the same or to transfer his interest therein to another licensee; and in case the surface rights have been granted, leased or located by the Crown to another person the licensee must proceed as provided in section 53 of this Act.

(2) If the working conditions have been complied with as hereinafter required for a period of four years on a claim of twenty chains square, or for three years on a claim of fifteen chains square or less, or when the equivalent of such working conditions has been complied with in a less period of time in the respective cases, the licensee may apply for and obtain a certificate of full performance of the working conditions for the claim free from any further working conditions, renewal fee or miner's license to work the same, and also a patent or lease for the land embraced in the claim, free from any further working conditions and miner's license to work the same upon a survey thereof being made, the boundary lines in such survey to follow the courses of the lines of the claim as originally staked out and recorded, or as the lines may have subsequently been altered, changed or corrected by the inspector, and upon payment therefor to the Department of Crown Lands of the purchase price of first year's rental at a rate per acre as provided in sections 41 and 45 respectively; and the time when the royalties may begin to be imposed or collected upon ores and minerals mined, wrought or taken from a claim so patented or leased shall be reckoned from the date of recording such claim in the Inspector's office; and the Commissioner of Crown Lands in granting patents under this subsection may grant at the same price to the owner of a claim any contiguous fraction or piece of land not staked of a less size than ten acres if surrounded by staked claims.

59. (1) A mining claim shall be deemed to be marked or staked out when a discovery post of wood or iron on which is written or stamped the name of the licensee is planted upon an outcropping or other indication of ore or mineral in place within the boundaries of the said claim, and a post of wood or iron is planted at each of the four corners in the order following, viz:— No. 1 at the northeast corner, No. 2 at the southeast corner, No. 3 at the southwest corner, No. 4 at the northwest corner, the number

in each case to be on the side of the post turned towards the post which follows in the order in which they are named, and if one or more corners of a claim fall in any situation where the nature or shape of the ground renders the planting of a post or posts impracticable, such corner or corners may be indicated by placing at the nearest suitable point a witness post, which in that case shall contain the same marks as those prescribed herein for corner posts, together with the letters W.P. and an indication of the bearing and distance of the site of the true corner from such witness post.

(2) Where there are standing trees upon a mining claim so staked out the licensee shall be required to blaze the trees and cut the underbrush along the boundary lines of the claim, and also along a line from the first corner post to the discovery post.

60. No more than one claim shall be staked out by any individual licensee upon the same vein, lode or deposit of ore or mineral unless such claim is distant at least sixty chains from the nearest known mine, claim or discovery on the same vein or lode; but no licensee shall stake out and record in the same mining division within a radius of fifteen miles more than four claims in one calendar year and for each additional claim after the first staked out and held by him he shall pay a fee of \$10 a year in advance, or such other sum as may be fixed by regulation.

61. (1) A mining claim shall be a square of fifteen chains, or 990 feet, containing twenty-two and one-half acres; or of such other extent, greater or less, as may be fixed by regulation for any mining division, but so as not to exceed a square of twenty chains or 1,320 feet, containing forty acres.

(2) Each mining claim shall be laid out with boundary lines running north and south and east and west astronomically and the measurements of each claim shall be horizontal and the ground included in each claim shall be deemed to be bounded under the surface by lines vertical to the horizon.

(3) A valuable water power lying within the limits of a claim shall not be deemed as part of it for the uses of the licensee and a road allowance of one chain in width shall be reserved along the water, together with such additional area as in the opinion of the Commissioner of Crown Lands may be necessary for the development and utilization of such water power.

62. (1) Every Inspector appointed under this Act shall keep a book for the recording therein of mining claims, which book shall be open to inspection by any person on payment of a fee of twenty cents; and every licensee who has marked or staked out a mining claim under this Act shall within thirty days thereafter supply under oath to the Inspector of the division an outline sketch or plan thereof showing the discovery post and the corner posts and the witness posts (if any), and their distances from each other in feet, together with a notice in writing setting forth the name of the licensee and the number of his license, the name (if any) of the claim and its locality as indicated by some general description or statement, the time when the same was marked or staked out, the length of the boundary lines, if for any cause they are not regular, and the nature of such cause, the situation of the discovery post as indicated by distance and direction from the first corner post and the date of the record; and the Inspector shall forthwith enter the particulars of the notice in his book, and shall file the notice and sketch or plan with the records of his office.

(2) If the licensee fails to comply with the provisions of this section so far as the same relate to him, or, if having complied with them, he or any person on his behalf shall remove any post for the purpose of changing the boundaries after the plan and notice have been filed, the mining claim so marked or staked out shall be deemed to be forfeited and abandoned and all right of the licensee therein shall cease.

63. (1) A mining claim shall also be deemed to be forfeited and abandoned and all right of the licensee therein shall cease in case the miner's license has run out and has not been renewed, or if the annual fee for the claim has not been prepaid, or if \$150 shall not be expended upon each claim taken up except as hereinafter in this section provided in stripping, or in opening up mines, in sinking shafts, or in other actual mining operations, exclusive of all houses, roads and other like improvements in every license year, and the said expenditure shall consist of labor actually performed by grown men, to be computed at the rate of \$2 per man per day; but when work upon a larger scale is required to be performed upon a claim valuable for iron ore, such requirements shall apply instead of the provisions of this subsection.

(2) Provided furthermore that for every five claims or less held by the same licensee or by different persons agreeing to combine their mining operations within a radius of one mile all such

mining operations may be carried on upon one of the claims; but notice of an intention to carry on such operations must be filed with the Inspector and a record of all mining operations carried on by a licensee during his license year, verified by oath, shall be filed with the Inspector, who shall enter an abstract thereof in his book.

(3) A licensee may at any time abandon a mining claim by giving notice in writing to the Inspector of the mining division of his intention so to do and from the date of the record of such notice in the Inspector's book all interest of the licensee in such claim shall cease.

64. No mining claim within a division shall be considered unworked within the meaning of the preceding section during the time that an Order in Council directs that work on mining claims within such mining division may be suspended.

65. Every licensee shall produce and exhibit his license to the Inspector for the division and prove to the satisfaction of the Inspector that it is in force, whenever required by him so to do.

ANNUAL STATISTICAL RETURNS.

78. (1) The owner or agent of every mine, quarry or other works to which this Part applies shall on or before the 15th day of January in every year send to the Bureau of Mines a correct return for the year ending on the preceding 31st day of December of the number of persons ordinarily employed in or about such mine below ground and above ground respectively, and distinguishing the different classes and ages of the persons so employed whose hours of labor are regulated by this Act, the average rate of wages of each class and the total amount of wages paid during the year, the quantity in standard weight of the mineral dressed and of the undressed mineral which has been sold, treated or used during such year, and the value or estimated value thereof; and the owner or agent of every metalliferous mine shall, if required, make similar returns at the end of each month or quarter of the calendar year for such month or quarter, in order that the same may be tabulated for publication by the Director of the Bureau under the instructions of the Commissioner of Crown Lands.

BIBLIOGRAPHY.

- CIRKEL, FRITZ—"Mica Deposits in the County of Ottawa," Transactions of the General Mining Association of the Province of Quebec, 1891, 1892, 1893.
- CIRKEL, FRITZ—"Mica Deposits," *Canadian Mining Review*, May, June and July, 1904.
- CORKILL—"Notes on the Occurrence, Production and Uses of Mica," Journal of the Canadian Mining Institute, Vol. VII.
- ELLS, Dr. R. W.—"Phosphate Deposits in the Laurentian," Transactions of the General Mining Association of the Province of Quebec, 1893.
- ELLS, Dr. R. W.—"Mica Deposits," Transactions of the Geological Society of America, 1894.
- GEOLOGICAL SURVEY OF CANADA, Reports of the—Years 1863, 1895, page 188L, 1896, page 85S, 1897, page 130S.
- HARRINGTON—"Report on the Minerals of some of the Apatite Bearing Veins of Ottawa County," Report of the Geological Survey of Canada, 1877-78.
- HOLLAND—"Mica in India," Memoirs Geological Survey of India, Vol. 34, part II, 1902.
- HOLMES—"Mica Deposits in the United States," Report of the United States Geological Survey, 1898-99.
- MINERAL INDUSTRY—Years 1898, 1899, 1900, 1901.
- OBALSKI—"Mica in the Saguenay District," Transactions of the General Mining Association of the Province of Quebec, 1894-95, page 24.
- OBALSKI—"Mica in the Province of Quebec," Report of the Quebec Bureau of Mines, 1901.
- ONTARIO BUREAU OF MINES, Reports of the—Years 1901, 1902, 1903.
- OSANN—"The Occurrence of Apatite and Mica North of Ottawa," Report of the Geological Survey of Canada, Vol. XII, 1899-1900.

PENROSE, Dr. R.—Bulletin United States Geological Survey, No. 46, 1888.

QUEBEC BUREAU OF MINES, Reports of the—Years 1901, 1902, 1903.

RAMMELSBERG—“Ueber die chemische Natur der Glimmer,” Sitzber. Akad., Berlin, 14th February, 1899.

SMITH, MERVYN—Institution of Mining and Metallurgy, 1898, page 168.

THURRSTON—“Mica in India,” Imperial Institute, Indian Section, No. 19.

TRAITÉ DE MINÉRALOGIE—2nd Ed., Vol. IV.

TSCHERMAK—“Die Glimmergruppe,” 1888.

INDEX.

	PAGES.
A	
Accessory minerals in pegmatite.	10-106
“ “ phlogopite deposits	25, 29, 31
Action of water in deposition of mica.	35
Adams, Dr., on syenite pegmatites.	10
Adams mine.	79
Alabama, U.S.A., mica in.	100
Allan, W. A., mine operator.	61
Alstead, New Hampshire, U.S.A., mica mine.	99
Alterations of mica.	5-102
American Mica Co.	56
Analyses of biotite	7
“ feldspar	16
“ muscovite	7
“ phlogopite	7-37
“ rare earths.	16-17
“ uranite.	16
Annual production in Canada	83
Annual returns of operations to Bureau of Mines	130
Apatite, cutting off deposits of mica.	33
“ early mining of.	20
“ igneous origin of.	35
“ in association with muscovite	14
“ “ “ phlogopite	25-32
“ inclusions in crystals.	6
“ occurrence with mica	32
Application for miners license, Prov. of Que	116
“ “ “ Prov. of Ont.	120
Applications of mica.	85
Aqueo-igneous solution of mica	35
Aqueous solution of mineral matter	36
Arbitration for mining on private lands, Prov. of Queb.	117
“ in claims for damages, Prov. of Ont.	125
Armatures, mica used in.	89
Artificial mica	8
Asbestos compound	95
“ paper, tests with	97
Atkinson, Mr. R.	95
Aylwin, Township of.	18

B

Baby mine.	26, 29, 78
Bahia, Brazil, mica in.	100
Bandathis, Indian miners.	108

Battle Lake mine	26, 28, 29, 46, 51
Beaulieu River	14
Beaver Lake claim	14
Bedford, Township of, mica mines	20, 22
Behar, India	103
Bendi, Hazaribagh	112
Bengal mica fields	104
Bengal mines	103
Bengal muscovite	5-105
Bengal Presidency	103
Bergeronnes River	14
Berthier, County of, occurrence of muscovite in	17
Beryl, as inclusions	6
" in pegmatite dikes	11-16
Bibliography	131-132
Biotite	3, 6, 10, 18
" composition	7
" in India	105
Birch Lake mine	77
Blackburn mine	32, 53, 83
Blake, Township of, occurrences of mica in	20
Blasting, cost of	40
Boiler coverings	91
Boiler insulations	91, 94, 95
Boom derricks	41
Bouchette, Township of, mica indiaations in	71
Brazil mica qualities	100
Brazil, productions of mica in	112
Brilliancy of mica colours	87
British Columbia	18
Brocades, mica used in	87
Bureau of Mines of Ontario	121
Burgess, Township of North and South, phlogopite deposits of	19, 20, 22, 80
Burke mine	66
Byrnes mine	78-79

C

Cable derricks, construction of	40-42
Calcite, in deposits in Templeton	32
" in deposits in Gatineau Valley	32
" in mica crystals	35
" mica in	25
Cambro Silurian formation	22
Canada Industrial Co., property of	54, 55, 57, 58
Canadian Mica & Mining Co.	15
Canadian Phosphate Co., properties of	60
Canadian production of mica	83
Cancelling of sale of mining lands, Prov. of Queb.	115
Capper, Prof., on uncovered steam pipes	92, 93, 94, 95

29, 46, 51	Carrier for cable derricks	43
14	Cascades, Gatineau River, pocket deposits at	31
14	Cassidy's mine	67-68
20, 22	Cavities, mica in	31
103	Cerium, oxide of	16-17
112	Ceylon mica, compared with Canadian	90
104	Chabot & Co., mine operators	59
103	Chaibee mine	71
5-105	Characteristics of the micas	3
103	Charlevoix County, occurrence of mineral cleveite in	18
14	Chicago Mica Co.	100
17	China, mica in	102
6	Chota Nagpur, India, mica in	103
11-16	Clay County, Alabama, U.S.A., occurrence of mica in	100
131-132	Cleavage	3
10, 18	Cleburn County, Alabama, U.S.A., occurrence of mica in	100
7	Cleveite	16
105	Cobbing of mica	44
77	Cochin, mica in, compared with Canadian	90
53, 83	Colour of mica	3, 5, 6
20	Commercial application of mica	85
40	Commercial sizes " "	47
91	Commercial value " "	90
94, 95	Commissioner of Crown Lands, Prov. of Quebec	113-114
41	Comparison of Canadian mica with other insulating material	95
71	Comparison of Indian with Canadian mica	90
100	Comparison of Indian with Canadian mining methods	111
112	Comparison of Ontario with Quebec mica fields	33
87	Composition of explosives	40
18	Composition of the micas. (See Analyses).	
87	Contact deposits	24-25
121	Contorted mica	36
2, 80	Cooling off of crystals	36
66	Cost of blasting	40
8-79	" of dynamite	40
	" hand drilling	39
	" labor in Canada	44
	" labor in India	111
	" machine drilling	40
	" mining	44
0-42	Crown Lands, definition, Prov. of Quebec	114
32	Crown mine, South Dakota, U.S.A.	100
32	Crystal colours, mica used in	87
35	Crystalline Limestone	22-23
25	Crystallization of mica	3
22	Crystals, imperfection of	6
58	" inclusions in	6-102
15	" intergrowth of	4
60	" subjected to earth pressure	7
83		
115		
95		

Cultivation of leased mining lands, Prov. of Ont.	125
Curtailement of production	83

D

Damages, arising from mining operations, Prov. of Quebec.	117
Danbury, New Hampshire, U.S.A., mica in	99
Davis mine.	99
Dawson, Dr. George, quoted, on value of Canadian mica	90
Dead rock in mining.	25-45
Debris, removal of.	40
Deep seated origin of mica deposits.	36
Delhi, India, mica mines in	103
Denholm, Township of, indications of mica in	71
Denver, Col., mica grinding works	88
Depth of drill holes.	39
Depth of mica deposits.	36
Derricks, boom derricks	40-41
" cable derricks.	42-43
Derry, Township of, mica in	20-61
Diamond Drill, use of, in Ontario	121
Dioritic dikes.	23-31
Director of Mining Bureau, Prov. of Ont.	121
Disposal of rock and mica	43
Disputes regarding mining, Prov. of Queb.	119
Distortion of crystals	3
Disturbing influences in formation of mica	31
Division of laminae and sheets	3
Drainage in Indian mines.	107
Dressing of mica in Canada.	47
" " in India.	108
Drilling in mica.	39
Dumko Gharanchi, mine, India.	103
Dumping cars	40
Dunstan, Wyndham, report on value of Canadian micas.	90
Duty on mica to United States	83
Dynamite, composition of	40
" cost of.	40

E

Eastmain River, occurrence of muscovite on.	19
Effect of hand-drilling	39
Effect of machine drilling.	40
Efficiency of Indian miner.	111
Efficiency of mica covering	97
Elasticity of mica	3-85
Electrical apparatus, use of mica in	90
Electrical non-conductivity of mica.	89
Electrical qualities of Canadian mica.	90

Electri
Electri
Ells, D
Empir
Englar
Epido
Errati
Europ
Exper
"
Exper
Explc
Explc
Expo
Faul
Faul
Feld
Fert
Film
Fire
Fiss
Fleu
Fle:
Fle:
For
For
For
For
Fra
Fra
Fra
Fu
Ga
Ga

125	Electricity for blasting	40
83	Electricity, used in mica mines	69
	Ells, Dr., quoted, on mica deposits	23
	Empire Mica Co.	99
	England, export of mica to	84
117	Epidote in pegmatite	11
99	Erratic methods of mining	82
99	Europeans mining in India	108
90	Experiments with Canadian mica	89-97
5-45	" " Indian mica	90
40	Experts opinion on Canadian mica	89
36	Exploratory drilling in Ontario	121
103	Explosives, cost of	40
71	" composition of	40
88	" in India	108-112
39	Exports of mica, from Canada	84
36	" " from India	103

F

	Faulting of veins, Hazaribagh	106
	Faults, lines of	31
	Feldspar, analysis of	16
	" in pegmatite dikes, Canada	9, 10, 11, 17
	" in pegmatite dikes, India	106-109
	" in Villeneuve mine	16
	" price in United States	16
	Fertilizers, mica used in	87
	Films, thickness of	48
	Fire screens, mica used in	85
	Fissure force	36
	Fleury mine	63
	Flexibility of mica	85
	Flexibility of micanite	90-89
	Fonseca mine, Brazil	100
	Forfeiture of mining claims	129
	Form of crystals	3,4
	Form of mining locations, Prov. of Ont.	121
	Fortin and Gravelle, mine operators	62
	Fracture, lines of	31
	Franchot, S. P.	15
	Free grant of mining locations, Prov. of Ont.	122
	Freeman's mine	76
	Free mining license	118
	Future possibilities of mica fields	85

G

	Gananoque, mica grinding mill	49
	Garnet in pegmatite in Canada	11
	" " in India	106

125
83

117
99
99
90
5-45
40
36
103
71
88
39
36
1-41
1-43
1-61
121
-31
121
43
119
3
31
3
07
47
08
39
03
40
90
83
40
40

9
19
0
1
7
5
0
9
0

Gatineau River, (mica belt)	22-31
" east side of, (mica mine on)	65
" west side of, (mica mine on)	62
Gatineau Valley	23-32
Gaya District, India	103
General Electric Co., (mica mines, etc.)	47, 71, 72, 78, 80, 83
Geographical distribution of the micas	8
Geographical distribution of phlogopite	20
Geological occurrence of muscovite	9
Geological occurrence of phlogopite	22
Glen Almond Mica & Mining Co.	61-62
Gneiss in the Laurentian	22-23
Gore of Templeton	59
Gould Lake mine	76
Goyaz, State of, (mica in)	100
Gracefield Station	72
Grades of mica, percentage of—in run of mine	46
Grading of mica	48
Grafton, New Hampshire, U.S.A., mica mine	99
Grand Trunk R.R., heat insulation tests with mica, conducted by	95-96
Granting of mining license, Prov. of Que.	117
Grenville mica deposits	19-20
Ground mica, cost of	49
Ground mica, preparation of	49-88
Gunpowder, use of—in India	112

H

Haacke, Mr. Albert, (experiments on condensation of steam in bare pipes by)	92
Hall mines	14
Hand drilling, effect and cost of	39
Hand press, for packing mica	47
Hanlan mine	78
Hardness of mica	7
Harrington Station, (mica mine at)	77
Hasawah, Indian sickle	108
Hazaribagh, India, faulting of veins in	106
" " feldspar in pegmatites	106
" " geological formation in	105
" " mica mines in	103
" " pegmatite veins	105
" " production of mica in	105
Haywood County, North Carolina, U.S.A., (mica deposits in)	100
Heat insulation, experiments with mica	94, 95, 96
High Rock mine	32-36
Hincks, Township of, (mica deposits in)	71
Hindoos mining mica	103
History of phlogopite	19
History of Indian mica mining	103

Hoists . . .
Horizon of
Hornblend
Hoskin's n
Hudson B
Hull, Tow
Hydrous s

Igneous o
Imperfect
Inclusion
India, Bi
India, ex
 " oc
Indian M
Indian m

"
"
"
"
"
"
"
"
"
"
"
"

Indian
Indian

Indiar

Inferi
Insulk
Insulk
Inter
Inter
Inter
Intru
Intru

22-31	Hoists.	43
65	Horizon of mica deposits	22
62	Hornblende gneiss in mica field	22
23-32	Hoskin's mine.	99
103	Hudson Beare, Prof., experiments of.	92, 93, 94
80, 83	Hull, Township of, mica deposits in.	62
8	Hydrous alterations of mica.	5

I

	Igneous origin of apatite.	35
	Imperfections of crystals	6
61-62	Inclusions in mica	5, 6, 102
22-23	India, Biotite in.	105
59	India, export of mica from.	103
76	“ occurrence of mica in.	105-106
100	Indian Mica Company	112
72	Indian mica, character of deposits of.	111
46	“ colour of.	3-111
48	“ dressing of	108, 109, 110
99	“ experiments with.	90
15-96	“ irregularity of supply	91
117	“ locations.	102-103
9-20	“ mineralogical features of.	111
49	“ outcrops of	108
9-88	“ prices of	110
112	“ production of	112
	Indian mica deposits, pockety nature of.	103
	Indian mica mines, breaking of rock in	108
	“ “ drainage of	107
92	“ “ efficiency of	111-112
14	“ “ life of.	112
39	“ “ number of.	103
47	“ “ number of persons employed in	103
78	“ “ production of	103
7	“ “ suspension of work in	108
77	“ “ ventilation of	107
108	“ “ wages in	111
106	Indian mica mining, history of	103
106	“ “ methods of.	106, 107, 108
105	“ “ methods of, compared with Canadian.	111
103	“ “ wastefulness of.	111
105	Inferior metals, mining concessions for.	114
05	Insulating power of mica	89
00	Insulation for steam pipes and boilers	91, 94, 95
96	Intergrowth of crystals.	4
36	Internal imperfections and inclusions.	6
71	International Mica Co.	49
03	Intrusion of pyroxene.	35
19	Intrusive character of pegmatite.	10
03	“ “ of pyroxene dikes.	23-36

Mica, history of	19-20	
“ hoisting of	41, 42, 43	Mining land
“ in cavities	3	“
“ inclusions	6	“
“ industry and status	82	Mining law
“ insulating power of	89	“
“ insulation for steam pipes and boilers	91	“
“ internal imperfections	6	Mining lice
“ market	89	“
“ mats for steam and hot water pipes	91	“
“ mattresses (see mats)		“
“ mines and locations	50	“
“ outcrops	34	“
“ percentage of—in rock	45	Mining lo
“ physical properties of	3	“
“ preparation of—sheets, sizes and thickness of	46-47	“
“ tests with—in locomotives	96-97	Mining ri
“ uses of	85	Mitchell C
“ waste	87	Mode of c
Mica Boiler Covering Co., Lmtd.	97	
Micaceous rock matter	31	Mohs' sca
Mica cutting factories	80	Monazite
Mica fields, in Canada, area of	20	Monghyr
“ “ geological features	22-23	Munsell,
“ “ topographical features	21	Murphy
“ in India	103	Muscovi
Mica mines, muscovite—in Ontario	18	“
“ “ Quebec	12	“
“ “ foreign countries	99	“
“ phlogopite—in Ontario	72	“
“ “ Quebec	50	“
Mica mining, cost of	44-45	“
“ in India	103	“
“ methods of	38	“
Mica Mining and Manufacturing Co.	56	“
Micanite	47-89	“
Michel, Mr., inventor of boiler covering	97	
Minas Geras, Brazil, occurrence of mica in	100	
Minerals on Crown lands, Prov. of Ont.	120	
Miners license, Prov. of Ont.	126	
“ duration of	126	Native
“ price of	126	Nelles
Mining Bureau, Prov. of Ont., functions of	121	Nellie
Mining claims, Prov. of Ont.	120	Nellor
Mining concessions in Prov. of Quebec	113, 114, 115	“
Mining lands, Prov. of Quebec, acquisition of	114	“
“ “ cancelling of sale of	115	New F
“ “ duties of proprietors of	114	Nilgit
“ “ sale of	114	Nitro
		Nitro

19-20
 41, 42, 43
 3
 6
 82
 89
 91
 6
 89
 91
 50
 34
 45
 3
 46-47
 96-97
 85
 87
 97
 31
 80
 20
 22-23
 21
 103
 18
 12
 99
 72
 50
 44-45
 103
 38
 56
 47-89
 97
 100
 120
 126
 126
 126
 121
 120
 115
 114
 115
 114
 114

Mining lands, Prov. of Ontario, cultivation of	125
“ “ in fee simple	122-123
“ “ leasing of	123
Mining law in Nellore, India	110
“ Prov. of Ontario	120
“ Prov. of Quebec	113
Mining license, Prov. of Quebec	114
“ application for	116
“ for exploring and prospecting	116
“ form of	117
“ free	118
“ granting and duration of	117
“ renewal of	117-118
Mining locations, Prov. of Ont., conditions on which to hold them	122
“ form, size and price of	121
“ grant of	122
Mining rights (see Mining law).	
Mitchell County, North Carolina, U.S.A., occurrence of mica in	100
Mode of occurrence of muscovite	9
“ phlogopite	23
Mohs' scale	7
Monazite	11-16
Monghyr District, India, mica areas in	103
Munsell, Eugene & Co., mica factory of	80
Murphy mine	58
Muscovite, apatite in connection with	14
“ applications of	85
“ geological occurrence of	9
“ in foreign countries	99
“ Brazil	100
“ China	102
“ India	102
“ Norway	102
“ United States	99
“ locations of	12
“ physical properties of	3

N

Native mining methods	108
Nelles mine	65
Nellie and Blanche mine	65
Nellore District, India, leasing of mica lands	110
“ “ mines in operation	} 110
“ “ output of mines	
“ “ persons employed	
New Hampshire, U.S.A, mica mines in	99
Nilgite District, India, mica areas of	103
Nitroglycerine, in dynamite	40
Nitroglycerine, mica as absorbent for	88

North Burgess, Township of, mica field in	78	Phlogopite,
North Carolina, U.S.A., mica mines in	99-100	“
Northfield, Township of, indications of mica in	71	“
North Star mine	32-36	“
Norway, mica in	102	“
O		
Obalski, quoted.	13-14	Phosphate
Oligoclas feldspar in Laurentian.	22	Phosphate
Ontario mica field,	72	Phosphate
“ compared with County of Ottawa	33	Physical p
Ontario, Province of —mining laws	120	Pike Lake
“ “ mining locations	18-72	Pitchblenc
Ontario, Province of —muscovite locations.	18	Pleochrois
“ “ phlogopite locations and mines	72	Pocket de
Ore reserves in mines	83	Pontiac, r
Origin of mica deposits.	35	Portland l
Ornamental uses of mica	86	“
Orthfield, Township of, mica deposits in.	20	Potash mi
Orthoclase gneiss in Laurentian	22	Preparati
Ottawa County	15, 20, 21	Pressure f
Outcrops of mica.	9-34	Price of g
Outcrops of mica in India.	106	“ of n
Output of Lake Girard mine	70	“ of n
“ Wallingford mine.	51	“ of r
		“ of p
		“ of s
P		
Packing of mica.	47-48	Primary
Paints, mica used in	86	Private l
Papagais mountains.	100	Process c
Parry Sound District	18	Producti
Patna, India	103	“
Pegmatite dikes.	10	“
“ in Hazaribagh, India.	105	“
“ intrusive character of	10	“
“ petrographic character of.	11	“
Percentage of grades in run of mine.	46	Product
“ mica in rock.	45-53	“
Percussion figures.	5	Propert
Perkins Mills, P. Que.	20, 26, 32	Prospec
Perth, Town of, mica district.	20, 21, 22, 23, 33	Protect
Petrographic character of Pegmatite.	11	Proudf
“ “ “ in India.	105	Publicl
Phlogopite	19	Pyrox
“ analyses of	37	“
“ comparisons of Canadian with India mica	90-91	“
“ crystallization of.	3	“
“ crystals in Lacey mine	6-75	Pyrox
“ deep seated origin of.	36	
“ geographical distribution of.	20	Qualiti

78	Phlogopite, geological occurrence of	22
99-100	“ history of	19
71	“ mines and locations.	50
32-36	“ primary crystals of	4
102	“ uses of.	86, 88, 89
	Phosphate (see Apatite).	
	Phosphate King mine.	32-33
13-14	Phosphate mines, early operation of.	20
22	Phosphate of lime.	35
72	Physical properties of mica	3
33	Pike Lake mine.	6, 78, 80
120	Pitchblende.	11-16
18-72	Pleochroism	6-76
18	Pocket deposits	24, 31, 38, 45
72	Pontiac, mica deposits in.	71
83	Portland East	61
35	“ West.	59
86	Potash mica.	3
20	Preparation of mica	47
22	Pressure figures	5
15, 20, 21	Price of ground mica.	49
9-34	“ of miners license, Prov. of Ont.	117
106	“ of mining concessions, Prov. of Que.	114-115
70	“ of mining locations, Prov. of Ont.	121
51	“ of muscovite.	84-110
	“ of phlogopite	84
	“ of scrap mica	49
47-48	Primary crystals.	4
86	Private lands, license on, Prov. of Que.	117
100	Process of grinding mica.	49
18	Production of mica in Brazil	112
103	“ “ Canada.	112
10	“ “ India.	102-112
105	“ “ Nellore, India.	110
10	“ “ United States.	112
11	“ “ the world	112
46	Productive mica fields in Canada	21-22
45-53	“ “ in India	103
5	Properties of Canadian mica	3, 89, 90
20, 26, 32	Prospecting licenses, Prov. of Que.	116
22, 23, 33	Protection of steam heated surfaces.	93
11	Proudfoot, Township of.	18
105	Public lands license.	117
19	Pyroxene	23, 31, 35, 36
37	“ in association with mica.	23
90-91	“ in contact with gneiss.	23
3	“ gneiss	22-35
6-75	Pyroxene dikes, intrusive character of	23, 26, 35
36		
20		
	Q	
	Qualities of mica for electrical purposes	89

Quarry mining	38, 40, 45
Quebec, Province of, mining concessions (see mining concessions)	
“ “ mining laws (see mining Laws)	
“ “ muscovite locations and mines	12
“ “ phlogopite locations and mines	50

R

Radium in cleveite	18
Rails, weight of	43
Randolph County, Alabama, U. S. A., mica in	100
Rare earths	11, 16, 17
Recording of mining claims, Prov. of Ont.	129
Removal of debris	40-41
Renewal of miners license	117-118
Reservation of timber on mining lands, Prov. of Ont	124
Reserves, ore—in mines	82-83
Returns of operations to Mining Bureau, Prov. of Ont.	130
Rheaume Lake mine	26, 28, 29, 53
Rhombohedral symmetry of mica	3
Ribbon mica	4, 5, 25
Rights of licensee of mining property, Prov. of Ont.	126
Roberts mine	77
Rock, blasting of	40
“ disposal of	41, 42, 43
“ drilling of	39-40
Rome, mica used in ancient	87
Ruggles mine	99
Run of mine	46

S

Saguenay district, mica locations	12-13
Samarskite	11-17
Santa Luzia de Carrangola	100
Scott mine	63
Scrap mica	49
Serpentine associated with pyroxene	67
Seybold mine	69
Shearing force, action of	36
Sherbrook, Township of South	22
Silicate cotton, tests with	97
Sills, Eddy Mica Co.	58, 72, 80
Singhoom district India	103
Size of mica sheets in Canada	46
“ “ in India	110
Size of mining concessions, Prov of Que.	113
“ locations, Prov. of Ont.	121
Skutterud, Norway	102
Smithonian Institution, investigation by	76
Smoke flues, protection of	91
Sorting of mica	43-44

South Dako
Spectacles, 1
Sporadical
St. Antoine
Stains in N
“ Vi
Staking an
Staking of
Statistics,
“
Status of C
Steam pip
Steel used
“
Stevensor
Stoness n
Storingt
Stoves, n
Substitur
Superior
Surface
Surface
Surveys
Sydenha
System

Temple
Temple
Tête Ja
Thin sp
Thoriu
Thuml
Timbe
Timbe
Timbe
Title t
Tonna
“
Topo
Total
Tour
Tran
Tran
Trim
Trin
Twir
Twis

Unc

Ungava, mica in	19
United States, duty on mica in	83
" export to.	84
" Geological Survey, quoted, on analysis of feldspar.	16
" mica locations	99-100
" production of mica	112
Uranium, oxide of—in uranite.	16-17

V

Valuation in case of damages by mining, Prov. of Ont.	125
Value of mica (see Prices).	
Valve seatings, mica used for.	88
Vavassour mine.	65
Veinlike mica deposits	25-38
Venosta station, existence of mica near.	18
Ventilation in mines	40
" in Indian mines	107
Victoria mine.	58
Villeneuve mine.	7, 11, 12, 15, 17

W

Wages in Canada	44-83
" in India.	111
Wainad, India, mica in.	109
Wakefield, Township of, mica mines in	26-68
Wakefield Mica Co.	26
Wallingford mine	26, 27, 32, 50, 83
Wall paper, mica used in	86
Warren French mine.	99
Wastefulness of Indian mining methods	111-112
Waste mica (see Scrap mica).	
Water power, rights to—in mining claims, Prov. of Ont.	128
" " " " in Prov. of Queb.	119
Water powers in mica fields	21
Weather, influence of—on quarry mining	38
White Bengal mica.	90
Windows, mica used in.	85
Winning of mica	39
" " in India.	106, 107, 108
Withdrawal of mineral lands from sale by Crown, Prov. of Ont.	120
World's production of mica.	112
Wright, Township of, mica properties in.	71

Y

Yancey County, North Carolina, U.S.A., mica in	100
Yttrium, oxide of, in uranite.	16-17

Z

Zircon, as inclusions	6
" in pegmatite dikes.	11